



Hutchison Hayes Separation Inc.

HH 1200



The HH 1200 centrifuge is a solids ejecting disc stack centrifuge designed for intermittently discharge of solids, while splitting a tight emulsion of two liquids.

Application

The HH 1200 system is specifically designed for a number of different separation duties, such as: purification, degumming, wash water removal, glycerin separation and clarification

Working principle:

Separation takes place inside a rotating bowl. The feed is introduced to the rotating centrifuge bowl from the top via a stationary inlet pipe and is accelerated in the distributor, before entering the disc stack. The distributor is designed especially to ensure smooth acceleration of the feed liquid. The separation of liquid-liquid-solids takes place between the discs, with the oil phase moving through the disc stack to the centre and is discharged through a paring disk pump. The water and solids separated from the oil moves out to the periphery, the water is led via channels in the top disc to the heavy phase paring chamber, where it is pumped out of the by a built-in paring disc. The solids are collected in the periphery,

from where it is discharged intermittently via the centrifuge cyclone. The solids discharge is achieved by a hydraulic system which at preset suitable intervals forces the sliding bowl bottom to drop down and thus opening the solids ports at the bowl periphery.

Installation

The HH 1200 separation system is designed for installation as a complete system. And can be delivered as loose components or as a complete turn-key module.

Options

A complete system includes a starter, PLC controls, valves, piping, feed pump and other equipment.

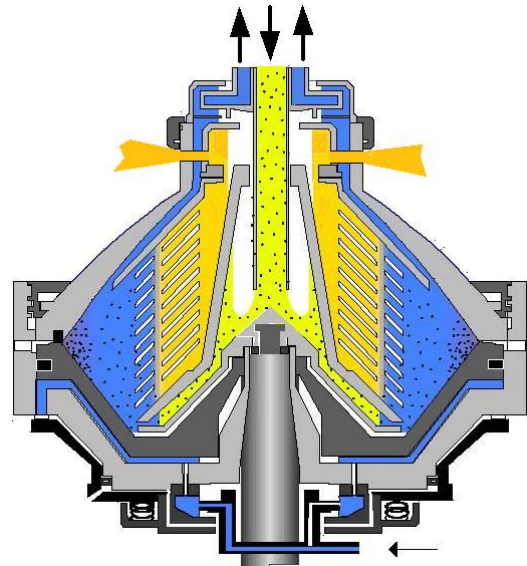

Hutchison Hayes Separation Inc.
3520 East Belt
Houston, Texas 77015, USA
Phone 713 455 9600

www.hutchisonhayes.com
P.O.Box 2965
Houston, Texas 77252, USA
Fax 713 455 7753



Hutchison Hayes Separation Inc.

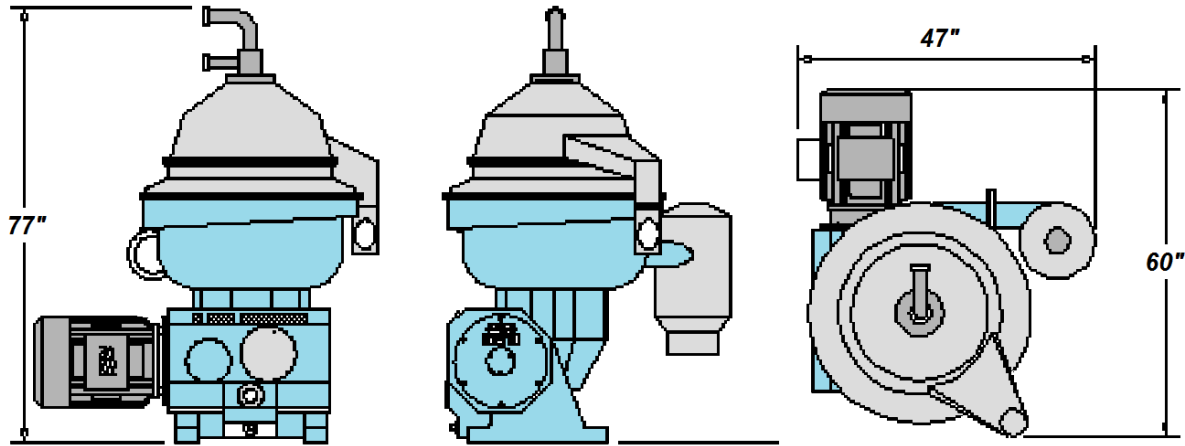

TECHNICAL DATA SHEET

MODEL HH-1200

MAXIMUM RATED CAPACITY	109 GPM	SPEED	
Minimum temperature	30°F	Drive motor	1750 RPM
Maximum temperature	212°F	Bowl Spindle	5125 RPM
Recommended throughput:		Run up time	12 minutes
Viscosity 14 cSt/40°C (104°F)	55 GPM	Run down time	30minutes
Viscosity 32-46 cSt/40°C (104°F)	47 GPM	Materials	
Delivery head pump	45 Feet, WC	Frame:	cast iron (epoxy enamel)
Sludge Holding Space	4 Gallon	Covers:	cast aluminum
Drive Motor	40 HP	Bowl body, hood, disc stack:	stainless steel
Gear Case Oil	3.2 Gallon	Distributor, top disc:	nickel plated bronze
Operating Water per discharge	7 gallon	Shipping Data	
Max chloride content	60 PPM	Unit is shipped with all necessary bowl tools, mounting isolators, built-on feed pump and motor.	
		Net weight	4000 Lbs
		Gross weight	4300 Lbs
		Volume	60 Cu. foot

Hutchison Hayes Separation Inc.
 3520 East Belt
 Houston, Texas 77015, USA
 Phone 713 455 9600

www.hutchisonhayes.com
 P.O.Box 2965
 Houston, Texas 77252, USA
 Fax 713 455 7753