

## **Hutchison-Hayes Separators, Inc.**

### **Model PX 90VGV-15CY Parts List With Diagrams**

**P.O. Box 2965 ♦ Houston, Texas 77252**  
**3520 East Belt ♦ Houston, Texas 77015**  
**(713) 455-9600 ♦ Fax (713) 455-7753**

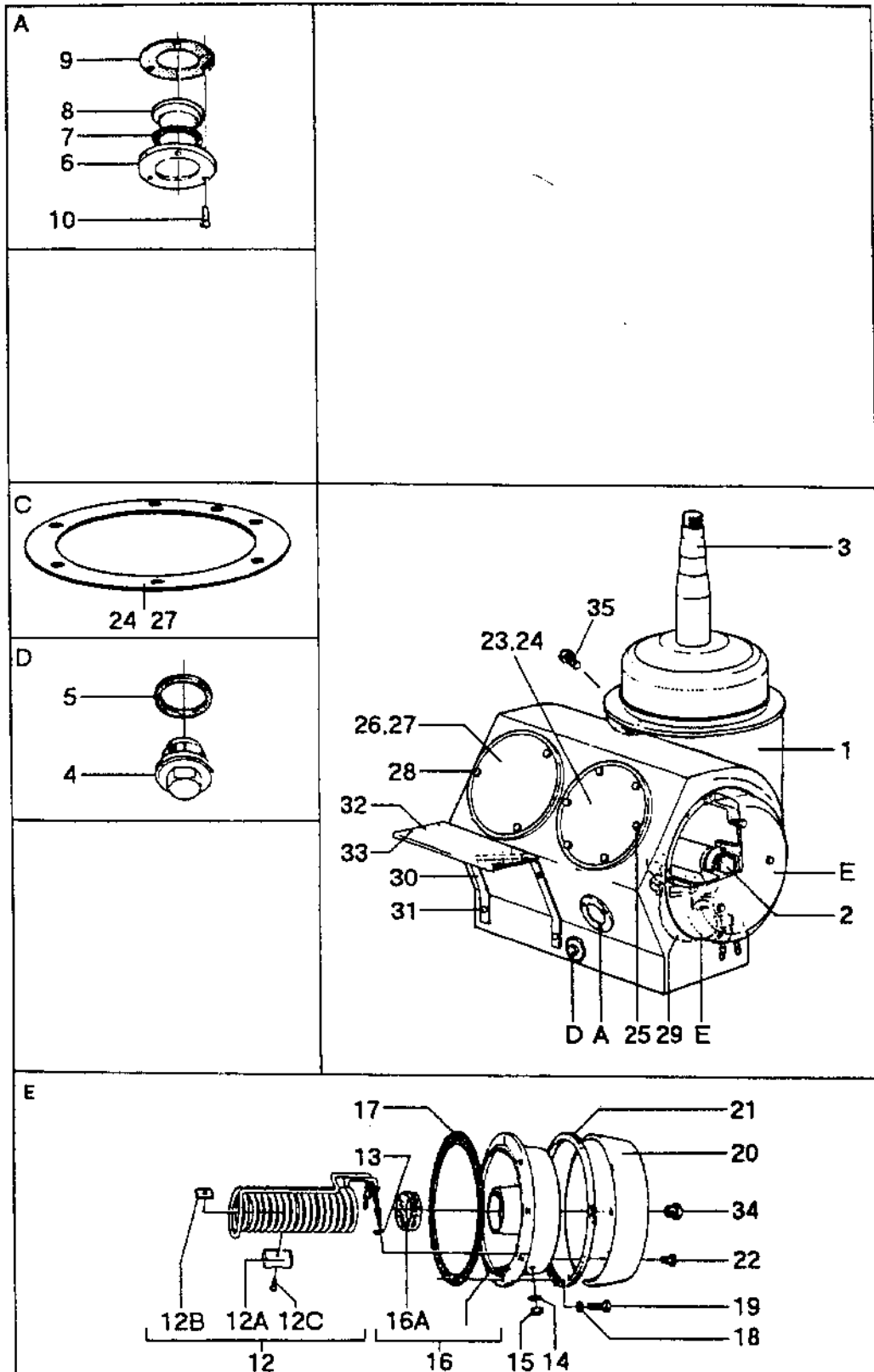

C-01224-04

|                               |   |
|-------------------------------|---|
| Machine type<br>PX 90VGV-15CY | Machine unit description<br>Machine bottom part<br>Subassembly description<br>Driving device horizontal |
|-------------------------------|---|

|                         |
|-------------------------|
| Page<br><b>010-1.1</b>  |
| Fig. ref<br>C-00085-D-5 |
| Date<br>94-12           |

| Ref. | Part No   | Description           | Machine unit No or<br>Subassembly description / Qty<br>546423 - |      |    |    |    |    |    | Notes |
|------|-----------|-----------------------|---|------|----|----|----|----|----|-------|
|      |           |                       | - 80  | - 81 |    |    |    |    |    |       |
| 1    | 544786 01 | Bearing housing.....  | 1   | 1    |    |    |    |    |    |       |
| 2    | 541985 01 | Round nut.....        | 1   | 1    |    |    |    |    |    |       |
| 3    | 546424 80 | Worm wheel shaft..... | 1   | 1    |    |    |    |    |    |       |
| 4    | 233211 04 | Ball bearing.....     | 1   | 1    |    |    |    |    |    |       |
| 5    | 67478     | Round nut.....        | 1   | 1    |    |    |    |    |    |       |
| 6    | 544789 01 | Lock ring.....        | 1   | 1    |    |    |    |    |    |       |
| 7    | 544950 01 | Worm wheel.....       | 1   | --   | -- | -- | -- | -- | -- | 50 Hz |
| 7    | 544950 02 | Worm wheel.....       | --  | 1    | -- | -- | -- | -- | -- | 60 Hz |
| 9    | 541988 01 | Clamp element.....    | 1   | 1    |    |    |    |    |    |       |
| 10   | 8379      | Ball bearing.....     | 1   | 1    |    |    |    |    |    |       |
| 11   | 544783 80 | Coupling disc.....    | 1   | 1    |    |    |    |    |    |       |
| 12   | 223610 32 | Flat key.....         | 1   | 1    |    |    |    |    |    |       |
| 13   | 260001 39 | Screw.....            | 1   | 1    |    |    |    |    |    |       |
| 14   | 223107 28 | Spring washer.....    | 1   | 1    |    |    |    |    |    |       |
| 15   | 541991 01 | Washer.....           | 1   | 1    |    |    |    |    |    |       |
| 16   | 80571     | Elastic plate.....    | 3   | 3    |    |    |    |    |    |       |

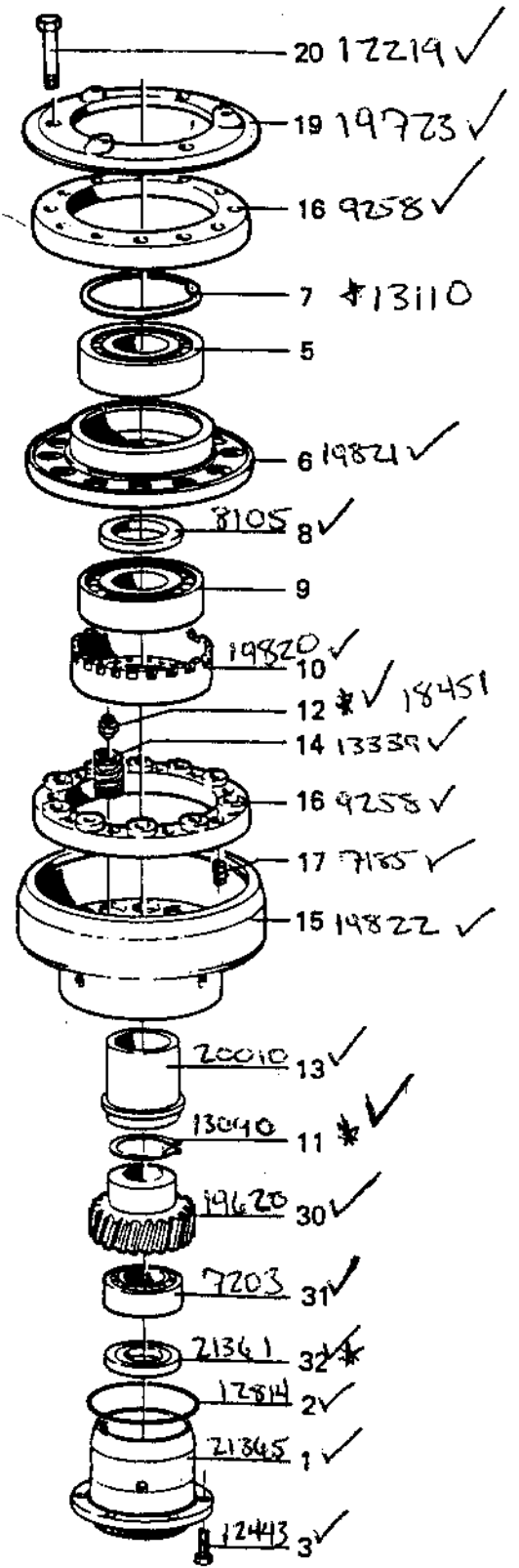
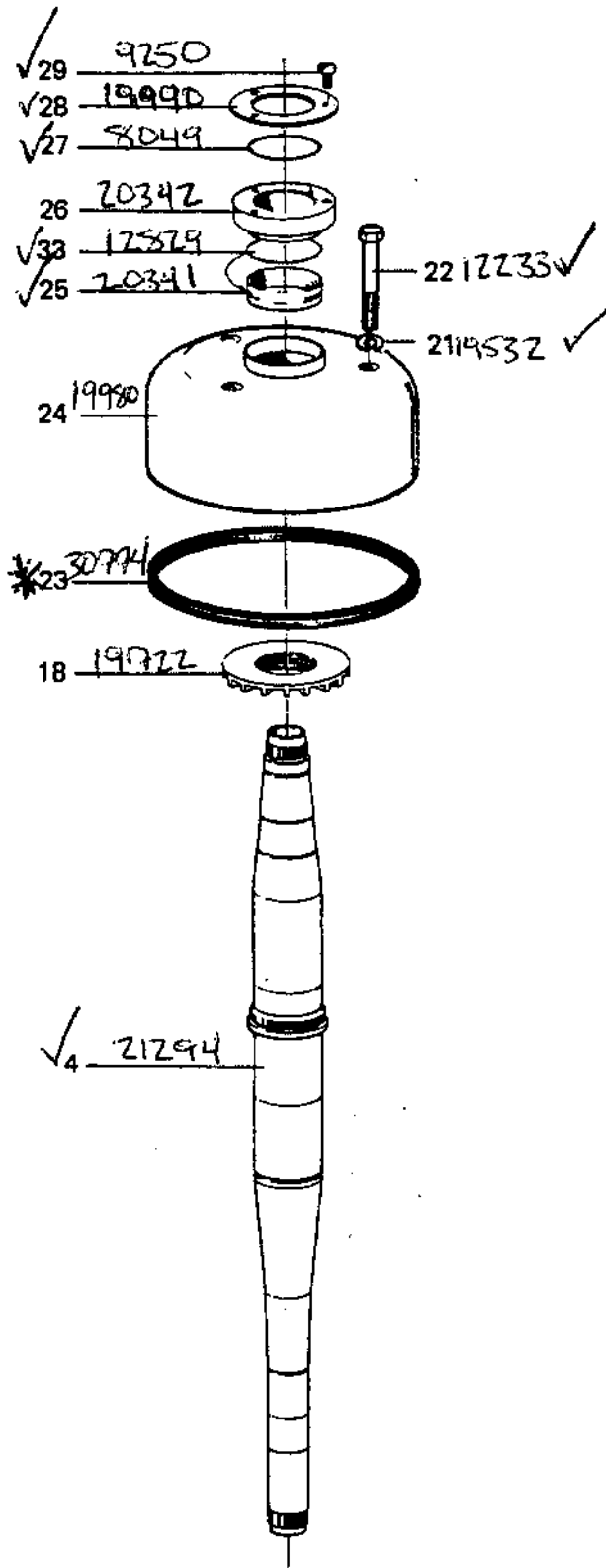

C-0031-04

|                               |   |
|-------------------------------|---|
| Machine type<br>PX 90VGV-15CY | Machine unit description<br>Machine bottom part |
|                               | Subassembly description                         |

|                         |
|-------------------------|
| Page<br><b>010-1</b>    |
| Fig. ref<br>C-01224-0-6 |
| Date<br>94-12           |

| Ref. | Part No   | Description                    | Machine unit No or Subassembly description / Qty<br>555398 - |      |  |  |  |  |  |  | Notes            |
|------|-----------|--------------------------------|--|------|--|--|--|--|--|--|------------------|
|      |           |                                | - 01   | - 02 |  |  |  |  |  |  |                  |
| -    | -         | For 50 Hz .....                | 1  | 1    |  |  |  |  |  |  |                  |
| -    | -         | For 60 Hz .....                | 1  | 1    |  |  |  |  |  |  |                  |
| 1    | 556407 80 | Frame bottom part compl.....   | 1  | 1    |  |  |  |  |  |  |                  |
| 2    | 546423 80 | Driving device horizontal..... | 1  | -    |  |  |  |  |  |  |                  |
| 2    | 546423 81 | Driving device horizontal..... | -  | 1    |  |  |  |  |  |  | See page 010-1.1 |
| 3    | 546800 85 | Driving device vertical.....   | 1  | -    |  |  |  |  |  |  | See page 010-1.1 |
| 3    | 546800 86 | Driving device vertical.....   | -  | 1    |  |  |  |  |  |  | See page 010-1.2 |
| 4    | 526189 01 | Drain screw.....               | 1  | 1    |  |  |  |  |  |  | See page 010-1.2 |
| 5    | 223316 05 | Rectangular ring .....         | 1  | 1    |  |  |  |  |  |  |                  |
| 6    | 523215 02 | Fixing plate .....             | 1  | 1    |  |  |  |  |  |  |                  |
| 7    | 37167     | Rectangular ring .....         | 1  | 1    |  |  |  |  |  |  |                  |
| 8    | 38685     | Glass disc .....               | 1  | 1    |  |  |  |  |  |  |                  |
| 9    | 528723 01 | Gasket .....                   | 1  | 1    |  |  |  |  |  |  |                  |
| 10   | 221131 08 | Screw .....                    | 3  | 3    |  |  |  |  |  |  |                  |
| 12   | 534126 85 | Cooling coil .....             | 1  | 1    |  |  |  |  |  |  |                  |
| 12A  | 534127 01 | Magnet.....                    | 1  | 1    |  |  |  |  |  |  |                  |
| 12B  | 534128 01 | Washer .....                   | 1  | 1    |  |  |  |  |  |  |                  |
| 12C  | 280250 05 | Screw .....                    | 1  | 1    |  |  |  |  |  |  |                  |
| 13   | 73665     | Rectangular ring .....         | 2  | 2    |  |  |  |  |  |  |                  |
| 14   | 223101 37 | Washer .....                   | 2  | 2    |  |  |  |  |  |  |                  |
| 15   | 526343 03 | Nut.....                       | 2  | 2    |  |  |  |  |  |  |                  |
| 16   | 543494 82 | Bearing shield .....           | 1  | 1    |  |  |  |  |  |  |                  |
| 16A  | 545063 03 | Tolerance ring.....            | 1  | 1    |  |  |  |  |  |  |                  |
| 17   | 43626     | Gasket.....                    | 1  | 1    |  |  |  |  |  |  |                  |
| 18   | 223101 61 | Washer .....                   | 8  | 8    |  |  |  |  |  |  |                  |
| 19   | 221041 01 | Screw.....                     | 8  | 8    |  |  |  |  |  |  |                  |
| 20   | 528709 03 | Guard.....                     | 1  | 1    |  |  |  |  |  |  |                  |
| 21   | 43630     | Seal strip.....                | 1  | 1    |  |  |  |  |  |  |                  |
| 22   | 221041 20 | Screw.....                     | 2  | 2    |  |  |  |  |  |  |                  |
| 23   | 555254 01 | Worm wheel guard.....          | 1  | 1    |  |  |  |  |  |  |                  |
| 24   | 528732 03 | Packing.....                   | 1  | 1    |  |  |  |  |  |  |                  |
| 25   | 221041 20 | Screw.....                     | 6  | 6    |  |  |  |  |  |  |                  |
| 26   | 545518 01 | Protecting cover.....          | 1  | 1    |  |  |  |  |  |  |                  |
| 27   | 528732 03 | Packing.....                   | 1  | 1    |  |  |  |  |  |  |                  |
| 28   | 221041 20 | Screw.....                     | 3  | 3    |  |  |  |  |  |  |                  |
| 29   | 554889 81 | Inlet device .....             | 1  | 1    |  |  |  |  |  |  |                  |
| 30   | 555320 01 | Holder.....                    | 2  | 2    |  |  |  |  |  |  | See page 010-1.3 |
| 31   | 221041 01 | Screw.....                     | 4  | 4    |  |  |  |  |  |  |                  |
| 32   | 555362 01 | Checked plate .....            | 1  | 1    |  |  |  |  |  |  |                  |
| 33   | 280256 02 | Screw.....                     | 4  | 4    |  |  |  |  |  |  |                  |
| 34   | 526350 04 | Plug .....                     | 1  | 1    |  |  |  |  |  |  |                  |
| 35   | 526350 04 | Plug .....                     | 1  | 1    |  |  |  |  |  |  |                  |

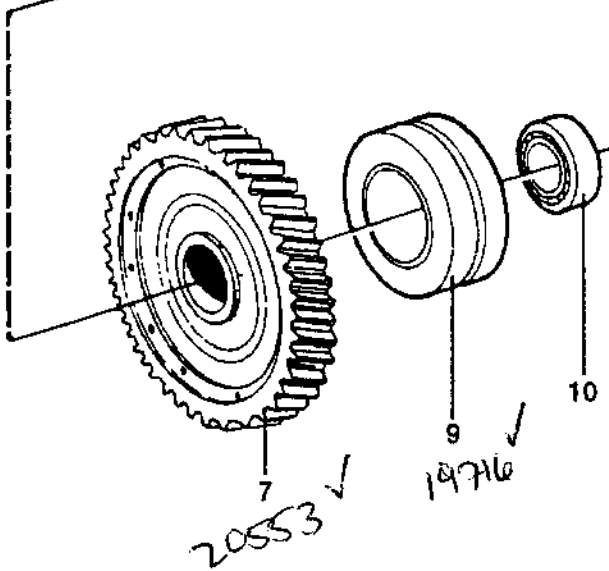
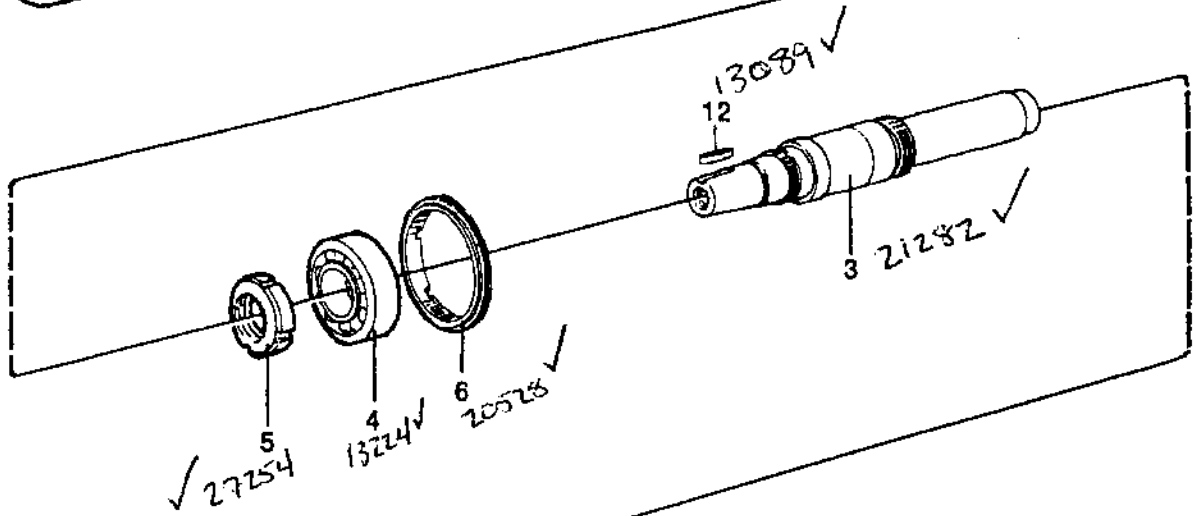
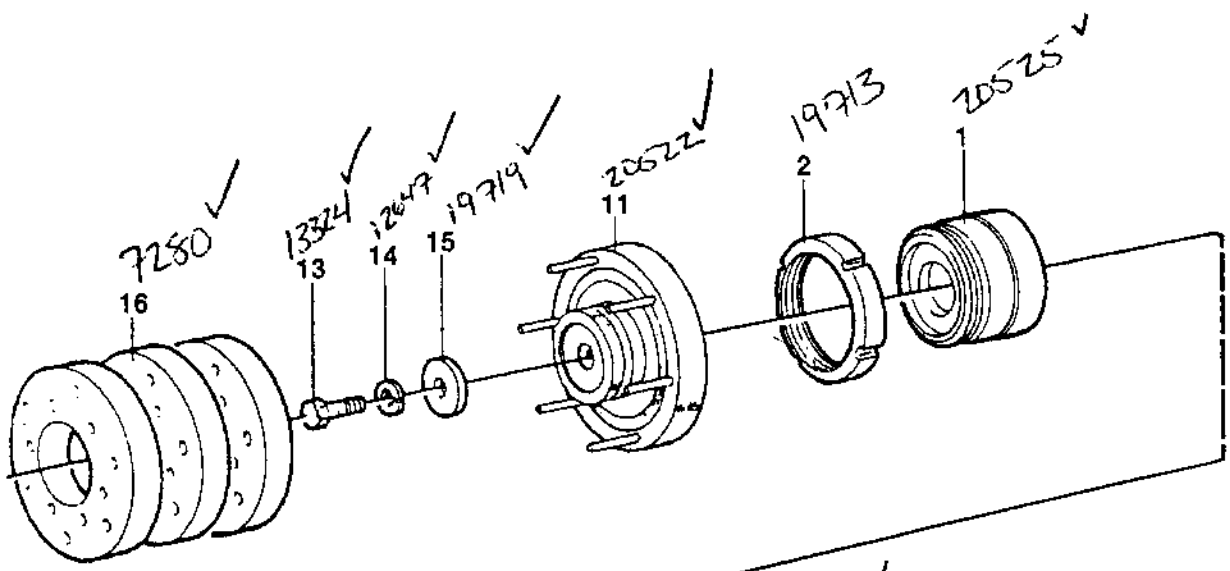

C-00005-04

|                               |   |
|-------------------------------|---|
| Machine type<br>PX 90VGV-15CY | Machine unit description<br>Machine bottom part<br>Subassembly description<br>Driving device vertical |
|-------------------------------|---|

|                         |
|-------------------------|
| Page<br>010-1.2         |
| Fig. ref<br>C-00331-0-2 |
| Date<br>94-12           |

| Ref. | Part No   | Description                 | Machine unit No or Subassembly description / Qty<br>546800 - |      |   |   |   |   |   | Notes |
|------|-----------|-----------------------------|--|------|---|---|---|---|---|-------|
|      |           |                             | - 85   | - 86 |   |   |   |   |   |       |
| 1    | 546607 01 | Bottom bearing housing..... | 1  | 1    |   |   |   |   |   |       |
| 2    | 223406 17 | O-ring.....                 | 1  | 1    |   |   |   |   |   |       |
| 3    | 221721 12 | Screw.....                  | 6  | 6    |   |   |   |   |   |       |
| 4    | 546439 01 | Bowl spindle.....           | 1  | 1    |   |   |   |   |   |       |
| 5    | 548747 07 | Ball bearing.....           | 1  | 1    |   |   |   |   |   |       |
| 6    | 542451 02 | Ball bearing housing.....   | 1  | 1    |   |   |   |   |   |       |
| 7    | 223642 49 | Snap ring.....              | 1  | 1    |   |   |   |   |   |       |
| 8    | 533415 01 | Spacing sleeve.....         | 1  | 1    |   |   |   |   |   |       |
| 9    | 548745 04 | Ball bearing.....           | 1  | 1    |   |   |   |   |   |       |
| 10   | 542450 02 | Bearing housing.....        | 1  | 1    |   |   |   |   |   |       |
| 11   | 223641 01 | Snap ring.....              | 1  | 1    |   |   |   |   |   |       |
| 12   | 538129 01 | Guide pin.....              | 12   | 12   |   |   |   |   |   |       |
| 13   | 543318 01 | Sleeve.....                 | 1  | 1    |   |   |   |   |   |       |
| 14   | 260083 41 | Compression spring.....     | 12   | 12   |   |   |   |   |   |       |
| 15   | 542452 02 | Top bearing support.....    | 1  | 1    |   |   |   |   |   |       |
| 16   | 529639 02 | Rubber buffer.....          | 2  | 2    |   |   |   |   |   |       |
| 17   | 70714     | Spring.....                 | 12   | 12   |   |   |   |   |   |       |
| 18   | 542026 02 | Oil fan.....                | 1  | 1    |   |   |   |   |   |       |
| 19   | 542027 02 | Top bearing cover.....      | 1  | 1    |   |   |   |   |   |       |
| 20   | 221045 35 | Screw.....                  | 3  | 3    |   |   |   |   |   |       |
| 21   | 541453 05 | Unit-ring.....              | 3  | 3    |   |   |   |   |   |       |
| 22   | 221046 16 | Screw.....                  | 3  | 3    |   |   |   |   |   |       |
| 23   | 555231 01 | Seal ring.....              | 1  | 1    |   |   |   |   |   |       |
| 24   | 543179 01 | Guard.....                  | 1  | 1    |   |   |   |   |   |       |
| 25   | 544271 01 | Seal ring.....              | 1  | 1    |   |   |   |   |   |       |
| 26   | 544272 01 | Protecting collar.....      | 1  | 1    |   |   |   |   |   |       |
| 27   | 223412 18 | O-ring.....                 | 1  | 1    |   |   |   |   |   |       |
| 28   | 543188 01 | Protecting plate.....       | 1  | 1    |   |   |   |   |   |       |
| 29   | 221131 07 | Screw.....                  | 3  | 3    |   |   |   |   |   |       |
| 30   | 541661 01 | Worm.....                   | 1  | -    | - | - | - | - | - | 50 Hz |
| 30   | 541661 02 | Worm.....                   | -  | 1    | - | - | - | - | - | 60 Hz |
| 31   | 548746 04 | Ball bearing.....           | 1  | 1    |   |   |   |   |   |       |
| 32   | 546601 01 | Protecting collar.....      | 1  | 1    |   |   |   |   |   |       |
| 33   | 223406 36 | O-ring.....                 | 1  | 1    |   |   |   |   |   |       |

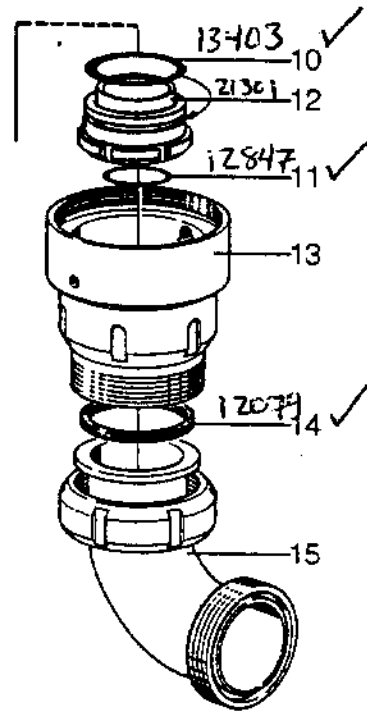
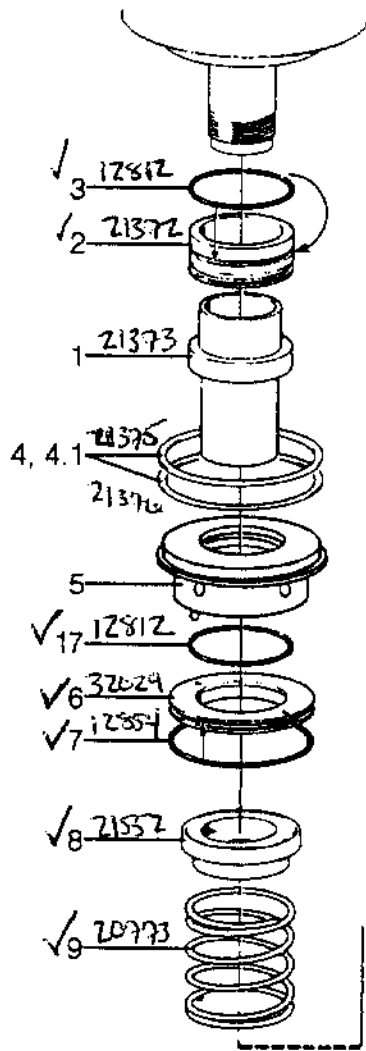

C-00730-0-6

|                                      |  |
|--------------------------------------|--|
| Machine type<br><b>PX 90VGV-15CY</b> | Machine unit description<br><b>Machine bottom part</b> |
|                                      | Subassembly description<br><b>Inlet device</b>         |

|                         |
|-------------------------|
| Page<br><b>010-1.3</b>  |
| Fig. ref<br>C-00730-0-5 |
| Date<br>94-12           |

| Ref. | Part No   | Description                 | Machine unit No or Subassembly description / Qty<br>554889 - |    |    |    |    |    |    | Notes      |
|------|-----------|-----------------------------|--|----|----|----|----|----|----|------------|
|      |           |                             | - 81   |    |    |    |    |    |    |            |
| 1    | 546636 01 | Sleeve.....                 | 1  |    |    |    |    |    |    |            |
| 2    | 546635 01 | Radiation ring .....        | 1  |    |    |    |    |    |    |            |
| 3    | 223406 15 | O-ring.....                 | 1  |    |    |    |    |    |    |            |
| 4    | 546637 01 | Height adjusting ring ..... | 3  | -- | -- | -- | -- | -- | -- | T = 1.0 mm |
| 4.1  | 546637 02 | Height adjusting ring ..... | 1  | -- | -- | -- | -- | -- | -- | T = 0.5 mm |
| 5    | 554317 80 | Intermediate part .....     | 1  |    |    |    |    |    |    |            |
| 6    | 554236 81 | Seal ring .....             | 1  |    |    |    |    |    |    |            |
| 7    | 223406 69 | O-ring.....                 | 1  |    |    |    |    |    |    |            |
| 8    | 547030 80 | Wear ring .....             | 1  |    |    |    |    |    |    |            |
| 9    | 545499 02 | Compression spring.....     | 1  |    |    |    |    |    |    |            |
| 10   | 260104 79 | O-ring.....                 | 1  |    |    |    |    |    |    |            |
| 11   | 223406 58 | O-ring.....                 | 1  |    |    |    |    |    |    |            |
| 12   | 546450 01 | Guide sleeve.....           | 1  |    |    |    |    |    |    |            |
| 13   | 554305 01 | Inlet housing .....         | 1  |    |    |    |    |    |    |            |
| 14   | 190605    | Rectangular ring .....      | 1  |    |    |    |    |    |    |            |
| 15   | 191033    | Elbow pipe .....            | 1  |    |    |    |    |    |    |            |
| 17   | 223406 15 | O-ring.....                 | 1  |    |    |    |    |    |    |            |

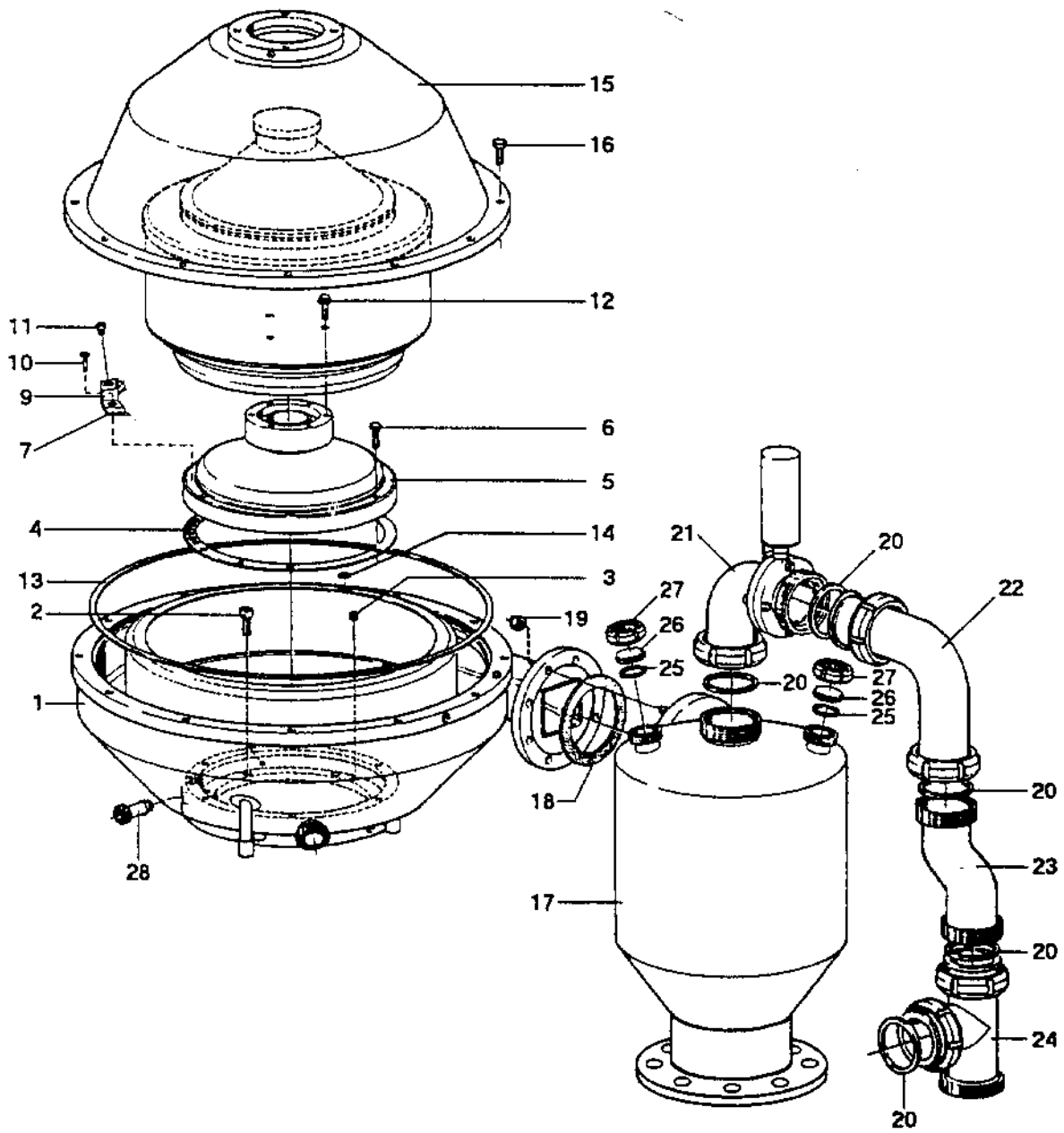

0-00880-0-1

|                                      |   |
|--------------------------------------|---|
| Machine type<br><b>PX 90VGV-15CY</b> | Machine unit description<br><b>Machine top part</b> |
|                                      | Subassembly description                             |

|                         |
|-------------------------|
| Page<br><b>020-1</b>    |
| Fig. ref<br>C-00860-0-5 |
| Date<br>94-12           |

| Ref. | Part No      | Description                    | Machine unit No or Subassembly description / Qty<br>555407 - |    |    |    |    |    |    | Notes            |
|------|--------------|--------------------------------|--|----|----|----|----|----|----|------------------|
|      |              |                                | - 04   |    |    |    |    |    |    |                  |
| 1    | 555160 80    | Frame top part .....           | 1  |    |    |    |    |    |    |                  |
| 2    | 221731 08    | Screw .....                    | 12   |    |    |    |    |    |    |                  |
| 3    | 260080 36    | Stop screw .....               | 3  |    |    |    |    |    |    |                  |
| 4    | 555245 01    | Height adjusting ring .....    | 6  |    |    |    |    |    |    |                  |
| 5    | 556560 80    | Paring disc device compl. .... | 1  | -- | -- | -- | -- | -- | -- | See page 020-1.1 |
| 6    | 221046 04    | Screw .....                    | 6  |    |    |    |    |    |    |                  |
| 7    | 555453 01    | Gasket .....                   | 1  |    |    |    |    |    |    |                  |
| 9    | 555447 01    | Nozzle holder .....            | 1  |    |    |    |    |    |    |                  |
| 10   | 221031 29    | Screw .....                    | 2  |    |    |    |    |    |    |                  |
| 11   | 542931 01    | Nozzle .....                   | 1  |    |    |    |    |    |    |                  |
| 12   | 545633 01    | Screw .....                    | 3  |    |    |    |    |    |    |                  |
| 13   | 547413 05    | Seal strip .....               | 1  |    |    |    |    |    |    |                  |
| 14   | 223406 25    | O-ring .....                   | 1  |    |    |    |    |    |    |                  |
| 15   | 544289 01    | Frame hood .....               | 1  |    |    |    |    |    |    |                  |
| 16   | 2 210463 23  | Screw .....                    | 12   |    |    |    |    |    |    |                  |
| 17   | 553284 80    | Cyclone .....                  | 1  |    |    |    |    |    |    |                  |
| 18   | 517774 34    | Gasket .....                   | 1  |    |    |    |    |    |    |                  |
| 19   | 221891 17    | Lock nut .....                 | 8  |    |    |    |    |    |    |                  |
| 20   | 190606       | Rectangular ring .....         | 5  |    |    |    |    |    |    |                  |
| 21   | 554011 81    | Ventilation pipe .....         | 1  |    |    |    |    |    |    |                  |
| 22   | 554017 80    | Elbow pipe .....               | 1  |    |    |    |    |    |    |                  |
| 23   | 555287 80    | Eccentric pipe .....           | 1  |    |    |    |    |    |    |                  |
| 24   | 31317 0882 2 | T-piece .....                  | 1  |    |    |    |    |    |    |                  |
| 25   | 190604       | Rectangular ring .....         | 2  |    |    |    |    |    |    |                  |
| 26   | 190087       | Washer .....                   | 2  |    |    |    |    |    |    |                  |
| 27   | 190616       | Coupling nut .....             | 2  |    |    |    |    |    |    |                  |
| 28   | 548634 80    | Pipe .....                     | 1  |    |    |    |    |    |    |                  |
| 29   | 556381 01    | Adapter .....                  | 1  |    |    |    |    |    |    |                  |
| 30   | 556384 01    | Adapter cap .....              | 1  |    |    |    |    |    |    |                  |

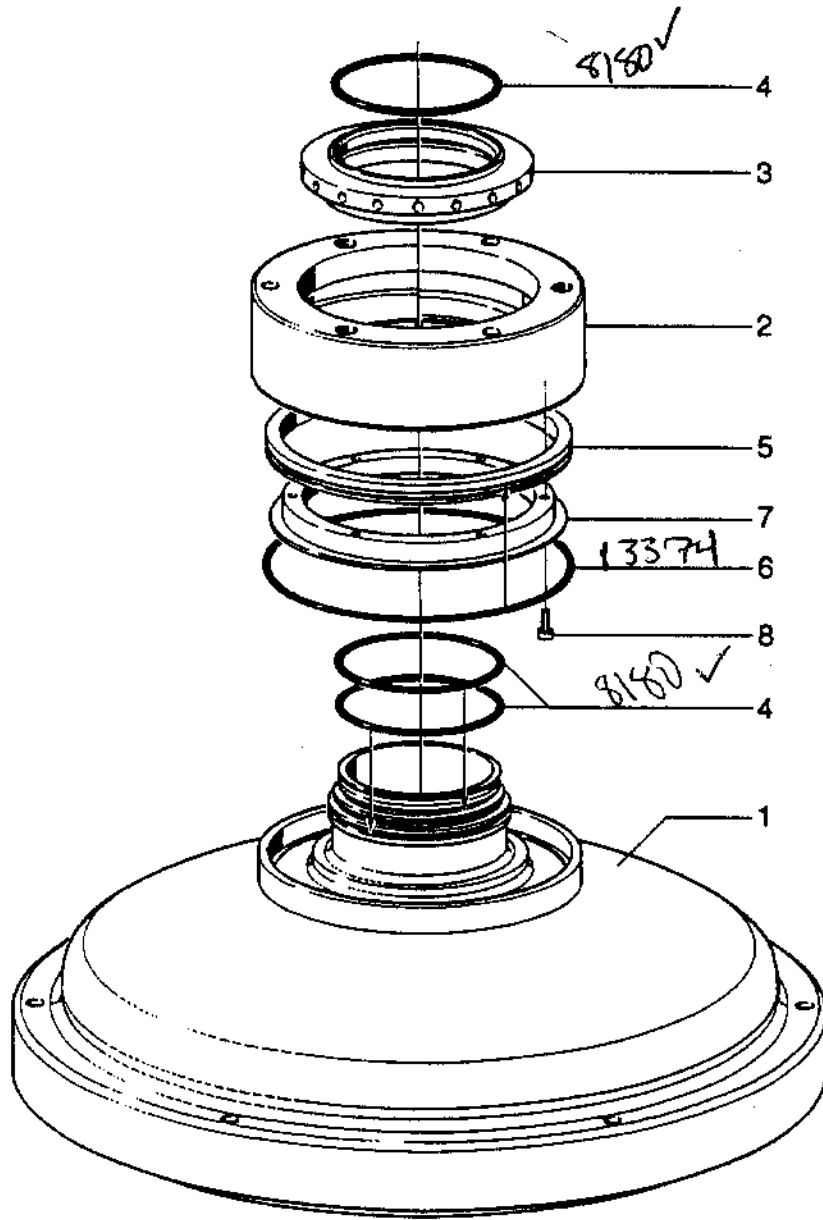

C-0001-0-8

|                               |  |                         |
|-------------------------------|--|-------------------------|
| Machine type<br>PX 90VGV-15CY | Machine unit description<br>Machine top part         | Page<br>020-1.1         |
|                               | Subassembly description<br>Paring disc device compl. | Fig. ref<br>C-00261-0-5 |
|                               |  | Date<br>94-12           |

| Ref. | Part No   | Description                  | Machine unit No or Subassembly description / Qty<br>556560 - |  |  |  |  |  |  |  | Notes |
|------|-----------|------------------------------|--|--|--|--|--|--|--|--|-------|
|      |           |                              | - 80   |  |  |  |  |  |  |  |       |
| 1    | 547970 02 | Distributing cover.....      | 1  |  |  |  |  |  |  |  |       |
| 2    | 554005 02 | Distributing ring compl..... | 1  |  |  |  |  |  |  |  |       |
| 3    | 554006 01 | Control paring disc.....     | 1  |  |  |  |  |  |  |  |       |
| 4    | 74634     | O-ring.....                  | 3  |  |  |  |  |  |  |  |       |
| 5    | 547971 01 | Throtting ring.....          | 1  |  |  |  |  |  |  |  |       |
| 6    | 260104 28 | O-ring.....                  | 1  |  |  |  |  |  |  |  |       |
| 7    | 547972 01 | Holder.....                  | 1  |  |  |  |  |  |  |  |       |
| 8    | 221701 13 | Screw.....                   | 6  |  |  |  |  |  |  |  |       |

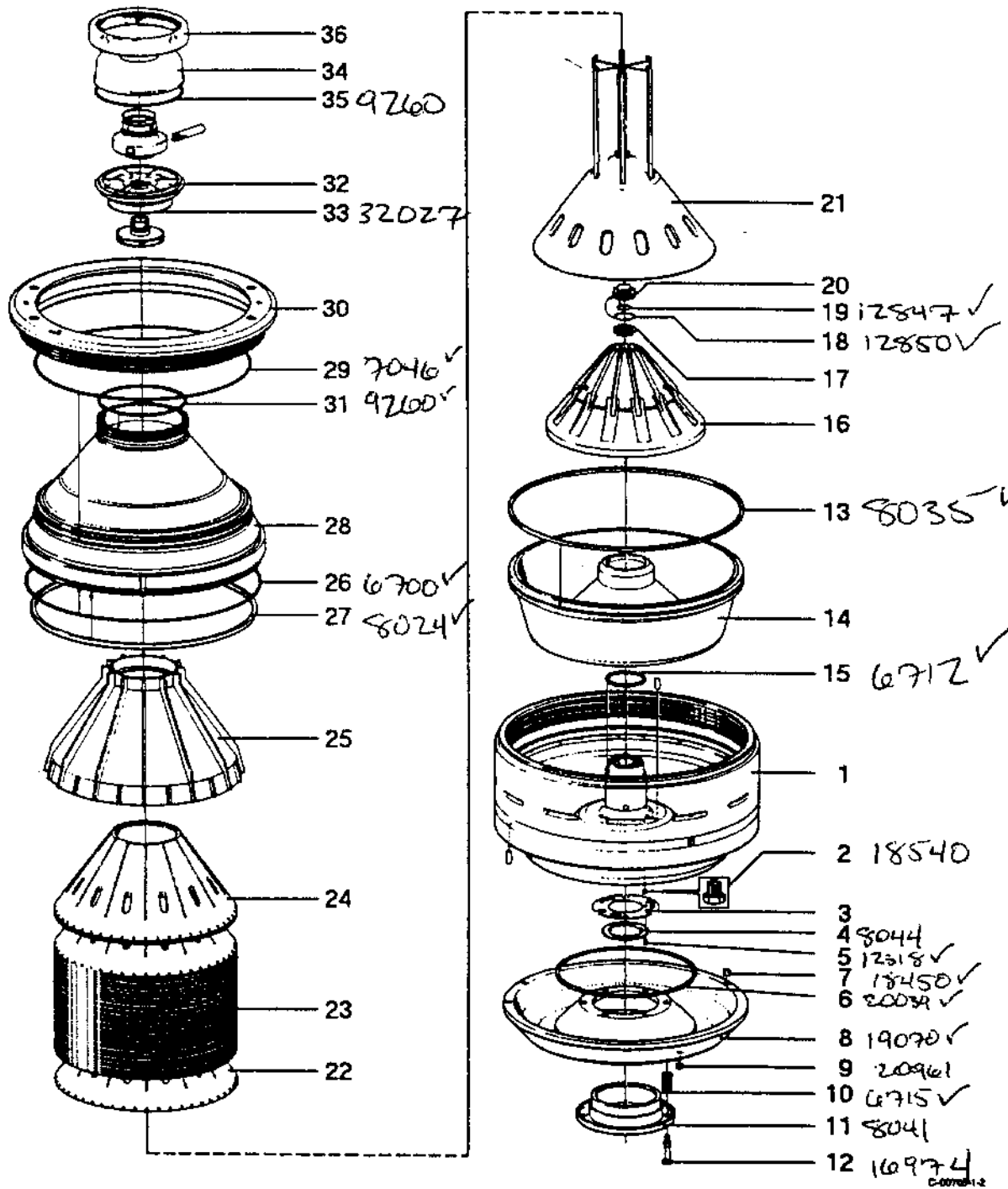

|               |                          |
|---------------|--------------------------|
| Machine type  | Machine unit description |
| PX 90VGV-15CY | Separator bowl           |
|               | Subassembly description  |

|              |
|--------------|
| Page         |
| <b>030-1</b> |
| Fig. ref     |
| C-00705-1-2  |
| Date         |
| 94-12        |

| Ref. | Part No   | Description                     | Machine unit No or Subassembly description / Qty |    |   |   |   |   |   | Notes |   |
|------|-----------|---------------------------------|--|----|---|---|---|---|---|-------|---|
|      |           |                                 | 555131 -   |    |   |   |   |   |   |       |   |
|      |           |                                 | - 02   |    |   |   |   |   |   |       |   |
| 1    | 553802 80 | Bowl body .....                 | 1  | -  | - | - | - | - | - | -     | ■ |
| 2    | 538124 08 | Nozzle 5 mm .....               | 1  |    |   |   |   |   |   |       |   |
| 3    | 543343 01 | Gasket .....                    | 1  |    |   |   |   |   |   |       |   |
| 4    | 529608 01 | Sleeve with wings .....         | 1  |    |   |   |   |   |   |       |   |
| 5    | 221131 03 | Screw .....                     | 3  |    |   |   |   |   |   |       |   |
| 6    | 543422 02 | Rectangular ring .....          | 1  |    |   |   |   |   |   |       |   |
| 7    | 537838 06 | Valve plug .....                | 3  |    |   |   |   |   |   |       |   |
| 8    | 539834 02 | Operating slide .....           | 1  | -- | - | - | - | - | - | -     | ■ |
| 9    | 545771 01 | Plug .....                      | 2  |    |   |   |   |   |   |       |   |
| 10   | 226214 74 | Spring .....                    | 24   |    |   |   |   |   |   |       |   |
| 11   | 541690 81 | Spring support .....            | 1  | -- | - | - | - | - | - | -     | ■ |
| 12   | 528168 02 | Screw .....                     | 6  |    |   |   |   |   |   |       |   |
| 13   | 523116 04 | Rectangular ring .....          | 1  |    |   |   |   |   |   |       |   |
| 14   | 545748 03 | Sliding bowl bottom .....       | 1  |    |   |   |   |   |   |       |   |
| 15   | 223416 35 | O-ring .....                    | 1  |    |   |   |   |   |   |       |   |
| 16   | 553804 81 | Distributing cone .....         | 1  |    |   |   |   |   |   |       |   |
| 17   | 542182 01 | Cap nut .....                   | 1  |    |   |   |   |   |   |       |   |
| 18   | 223406 64 | O-ring .....                    | 1  |    |   |   |   |   |   |       |   |
| 19   | 223406 58 | O-ring .....                    | 1  |    |   |   |   |   |   |       |   |
| 20   | 556532 02 | Sleeve with wings .....         | 1  |    |   |   |   |   |   |       |   |
| 21   | 553729 01 | Distributor .....               | 1  | -  | - | - | - | - | - | -     | ■ |
| 22   | 553920 81 | Bottom disc .....               | 1  |    |   |   |   |   |   |       |   |
| 23   | 553920 80 | Bowl disc .....                 | 153  |    |   |   |   |   |   |       |   |
| 24   | 553920 80 | Bowl disc .....                 | 3  |    |   |   |   |   |   |       |   |
| 25   | 553696 02 | Top disc .....                  | 1  | -- | - | - | - | - | - | -     | ■ |
| 26   | 521863 02 | Rectangular ring .....          | 1  |    |   |   |   |   |   |       |   |
| 27   | 543170 01 | Seal ring .....                 | 1  |    |   |   |   |   |   |       |   |
| 28   | 553757 01 | Bowl hood .....                 | 1  | -- | - | - | - | - | - | -     | ■ |
| 29   | 74355     | O-ring .....                    | 1  |    |   |   |   |   |   |       |   |
| 30   | 553764 01 | Lock ring .....                 | 1  | -- | - | - | - | - | - | -     | ■ |
| 31   | 223412 06 | O-ring .....                    | 1  |    |   |   |   |   |   |       |   |
| 32   | 553845 04 | Paring chamber cover low .....  | 1  |    |   |   |   |   |   |       |   |
| 33   | 223406 75 | O-ring .....                    | 1  |    |   |   |   |   |   |       |   |
| 34   | 553894 04 | Paring chamb. cover upper ..... | 1  |    |   |   |   |   |   |       |   |
| 35   | 223412 06 | O-ring .....                    | 1  |    |   |   |   |   |   |       |   |
| 36   | 553706 01 | Lock ring .....                 | 1  |    |   |   |   |   |   |       |   |

■ Utbyte nödvändig för ombalansering av kulan. Exchange necessitates rebalancing of bowl. Austausch erfordert Wiederauswuchtung der Trommel. L'échange nécessite le rééquilibrage du bol. El cambio hace necesario un nuevo equilibrado del rotor. La sostituzione comporta la riequilibratura del tamburo. A substituição exige o reequilíbrio do rotor. Vaihdettaessa kuula tasapainotettava uudelleen.

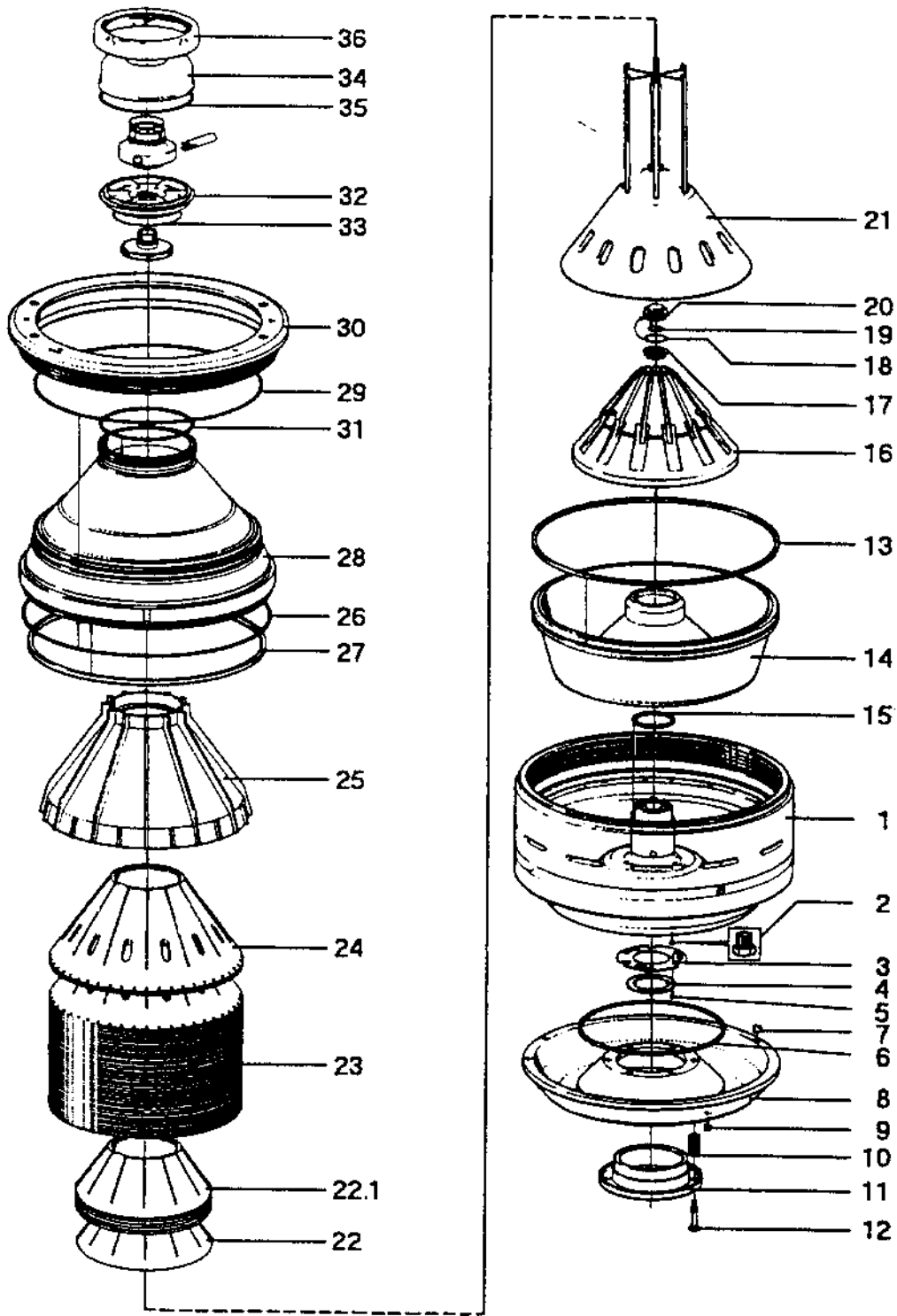

C-00708-1.7

|               |                          |
|---------------|--------------------------|
| Machine type  | Machine unit description |
| PX 90VGV-15CY | Separator bowl           |
|               | Subassembly description  |

|                         |
|-------------------------|
| Page<br><b>030-2</b>    |
| Fig. ref<br>C-00705-1-7 |
| Date<br>94-12           |

| Ref. | Part No   | Description                    | Machine unit No or Subassembly description / Qty |    |    |    |    |    |    |   | Notes |
|------|-----------|--------------------------------|--|----|----|----|----|----|----|---|-------|
|      |           |                                | 556313 -   |    |    |    |    |    |    |   |       |
|      |           |                                | - 02   |    |    |    |    |    |    |   |       |
| 1    | 553802 80 | Bowl body .....                | 1  | -- | -- | -- | -- | -- | -- | ■ |       |
| 2    | 538124 08 | Nozzle 5 mm.....               | 1  |    |    |    |    |    |    |   |       |
| 3    | 543343 01 | Gasket.....                    | 1  |    |    |    |    |    |    |   |       |
| 4    | 529608 01 | Sleeve with wings .....        | 1  |    |    |    |    |    |    |   |       |
| 5    | 221131 03 | Screw.....                     | 3  |    |    |    |    |    |    |   |       |
| 6    | 543422 02 | Rectangular ring .....         | 1  |    |    |    |    |    |    |   |       |
| 7    | 537838 06 | Valve plug .....               | 3  |    |    |    |    |    |    |   |       |
| 8    | 539834 02 | Operating slide .....          | 1  | -- | -- | -- | -- | -- | -- | ■ |       |
| 9    | 545771 01 | Plug .....                     | 2  |    |    |    |    |    |    |   |       |
| 10   | 226214 74 | Spring .....                   | 24   |    |    |    |    |    |    |   |       |
| 11   | 541690 81 | Spring support .....           | 1  | -- | -- | -- | -- | -- | -- | ■ |       |
| 12   | 528168 02 | Screw.....                     | 6  |    |    |    |    |    |    |   |       |
| 13   | 523116 04 | Rectangular ring .....         | 1  |    |    |    |    |    |    |   |       |
| 14   | 545748 03 | Sliding bowl bottom.....       | 1  |    |    |    |    |    |    |   |       |
| 15   | 223416 35 | O-ring.....                    | 1  |    |    |    |    |    |    |   |       |
| 16   | 553804 81 | Distributing cone.....         | 1  |    |    |    |    |    |    |   |       |
| 17   | 542182 01 | Cap nut.....                   | 1  |    |    |    |    |    |    |   |       |
| 18   | 223406 64 | O-ring.....                    | 1  |    |    |    |    |    |    |   |       |
| 19   | 223406 58 | O-ring.....                    | 1  |    |    |    |    |    |    |   |       |
| 20   | 556532 02 | Sleeve with wings .....        | 1  |    |    |    |    |    |    |   |       |
| 21   | 553729 01 | Distributor .....              | 1  | -- | -- | -- | -- | -- | -- | ■ |       |
| 22   | 555528 81 | Bottom disc.....               | 1  |    |    |    |    |    |    |   |       |
| 22.1 | 555528 80 | Bowl disc .....                | 19   |    |    |    |    |    |    |   |       |
| 23   | 553920 80 | Bowl disc .....                | 134  |    |    |    |    |    |    |   |       |
| 24   | 553920 80 | Bowl disc .....                | 2  |    |    |    |    |    |    |   |       |
| 25   | 553696 02 | Top disc.....                  | 1  | -- | -- | -- | -- | -- | -- | ■ |       |
| 26   | 521863 02 | Rectangular ring .....         | 1  |    |    |    |    |    |    |   |       |
| 27   | 543170 01 | Seal ring .....                | 1  |    |    |    |    |    |    |   |       |
| 28   | 553757 01 | Bowl hood.....                 | 1  | -- | -- | -- | -- | -- | -- | ■ |       |
| 29   | 74355     | O-ring.....                    | 1  |    |    |    |    |    |    |   |       |
| 30   | 553764 01 | Lock ring .....                | 1  | -- | -- | -- | -- | -- | -- | ■ |       |
| 31   | 223412 06 | O-ring.....                    | 1  |    |    |    |    |    |    |   |       |
| 32   | 553845 04 | Paring chamber cover low ..... | 1  |    |    |    |    |    |    |   |       |
| 33   | 223406 75 | O-ring.....                    | 1  |    |    |    |    |    |    |   |       |
| 34   | 553894 04 | Paring chamb. cover upper..... | 1  |    |    |    |    |    |    |   |       |
| 35   | 223412 06 | O-ring.....                    | 1  |    |    |    |    |    |    |   |       |
| 36   | 553706 01 | Lock ring .....                | 1  |    |    |    |    |    |    |   |       |

■ Utbyte nödvändig för ombalansering av kulan. Exchange necessitates rebalancing of bowl. Austausch erfordert Wiederauswuchtung der Trommel. L'échange nécessite le rééquilibrage du bol. El cambio hace necesario un nuevo equilibrio del rotor. La sostituzione comporta la riequilibratura del tamburo. A substituição exige o reequilíbrio do rotor. Vaihdettaessa kuula tasapainoitettava uudelleen.



|               |                          |                         |
|---------------|--------------------------|-------------------------|
| Machine type  | Machine unit description | Page                    |
| PX 90VGV-15CY | Separator bowl           | 030-3                   |
|               | Subassembly description  | Fig. ref<br>C-00705-1-B |
|               |                          | Date<br>94-12           |

| Ref. | Part No   | Description                     | Machine unit No or Subassembly description / Qty |  |  |  |  |  |  |  | Notes |
|------|-----------|---------------------------------|--|--|--|--|--|--|--|--|-------|
|      |           |                                 | 556314 -   |  |  |  |  |  |  |  |       |
|      |           |                                 | - 02   |  |  |  |  |  |  |  |       |
| 1    | 553802 80 | Bowl body .....                 | 1  |  |  |  |  |  |  |  | ■     |
| 2    | 538124 08 | Nozzle 5 mm .....               | 1  |  |  |  |  |  |  |  |       |
| 3    | 543343 01 | Gasket .....                    | 1  |  |  |  |  |  |  |  |       |
| 4    | 529608 01 | Sleeve with wings .....         | 1  |  |  |  |  |  |  |  |       |
| 5    | 221131 03 | Screw .....                     | 3  |  |  |  |  |  |  |  |       |
| 6    | 543422 02 | Rectangular ring .....          | 1  |  |  |  |  |  |  |  |       |
| 7    | 537838 08 | Valve plug .....                | 3  |  |  |  |  |  |  |  |       |
| 8    | 539834 02 | Operating slide .....           | 1  |  |  |  |  |  |  |  | ■     |
| 9    | 545771 01 | Plug .....                      | 2  |  |  |  |  |  |  |  |       |
| 10   | 226214 74 | Spring .....                    | 24   |  |  |  |  |  |  |  |       |
| 11   | 541690 81 | Spring support .....            | 1  |  |  |  |  |  |  |  | ■     |
| 12   | 528168 02 | Screw .....                     | 6  |  |  |  |  |  |  |  |       |
| 13   | 523116 04 | Rectangular ring .....          | 1  |  |  |  |  |  |  |  |       |
| 14   | 545748 03 | Sliding bowl bottom .....       | 1  |  |  |  |  |  |  |  |       |
| 15   | 223416 35 | O-ring .....                    | 1  |  |  |  |  |  |  |  |       |
| 16   | 553804 81 | Distributing cone .....         | 1  |  |  |  |  |  |  |  |       |
| 17   | 542182 01 | Cap nut .....                   | 1  |  |  |  |  |  |  |  |       |
| 18   | 223406 64 | O-ring .....                    | 1  |  |  |  |  |  |  |  |       |
| 19   | 223406 58 | O-ring .....                    | 1  |  |  |  |  |  |  |  |       |
| 20   | 556532 02 | Sleeve with wings .....         | 1  |  |  |  |  |  |  |  | ■     |
| 21   | 553729 01 | Distributor .....               | 1  |  |  |  |  |  |  |  |       |
| 22   | 555528 81 | Bottom disc .....               | 1  |  |  |  |  |  |  |  |       |
| 22.1 | 555528 80 | Bowl disc .....                 | 19   |  |  |  |  |  |  |  |       |
| 23   | 553920 80 | Bowl disc .....                 | 67   |  |  |  |  |  |  |  |       |
| 24   | 553920 80 | Bowl disc .....                 | 1  |  |  |  |  |  |  |  |       |
| 24.1 | 555528 80 | Bowl disc .....                 | 67   |  |  |  |  |  |  |  |       |
| 24.2 | 555528 80 | Bowl disc .....                 | 1  |  |  |  |  |  |  |  | ■     |
| 25   | 553696 02 | Top disc .....                  | 1  |  |  |  |  |  |  |  | ■     |
| 26   | 521863 02 | Rectangular ring .....          | 1  |  |  |  |  |  |  |  |       |
| 27   | 543170 01 | Seal ring .....                 | 1  |  |  |  |  |  |  |  | ■     |
| 28   | 553757 01 | Bowl hood .....                 | 1  |  |  |  |  |  |  |  | ■     |
| 29   | 74355     | O-ring .....                    | 1  |  |  |  |  |  |  |  | ■     |
| 30   | 553764 01 | Lock ring .....                 | 1  |  |  |  |  |  |  |  |       |
| 31   | 223412 06 | O-ring .....                    | 1  |  |  |  |  |  |  |  |       |
| 32   | 553845 04 | Paring chamber cover low .....  | 1  |  |  |  |  |  |  |  |       |
| 33   | 223406 75 | O-ring .....                    | 1  |  |  |  |  |  |  |  |       |
| 34   | 553894 04 | Paring chamb. cover upper ..... | 1  |  |  |  |  |  |  |  |       |
| 35   | 223412 06 | O-ring .....                    | 1  |  |  |  |  |  |  |  |       |
| 36   | 553706 01 | Lock ring .....                 | 1  |  |  |  |  |  |  |  |       |

■ Utbyte nödvändigt för ombalansering av kulan. Exchange necessitates rebalancing of bowl. Austausch erfordert Wiederauswuchtung der Trommel. L'échange nécessite le rééquilibrage du bol. El cambio hace necesario un nuevo equilibrado del rotor. La sustitución comporta la riequilibratura del tamburo. A substituição exige o reequilíbrio do rotor. Vaihdettaessa kula tasapainoitettava uudelleen.

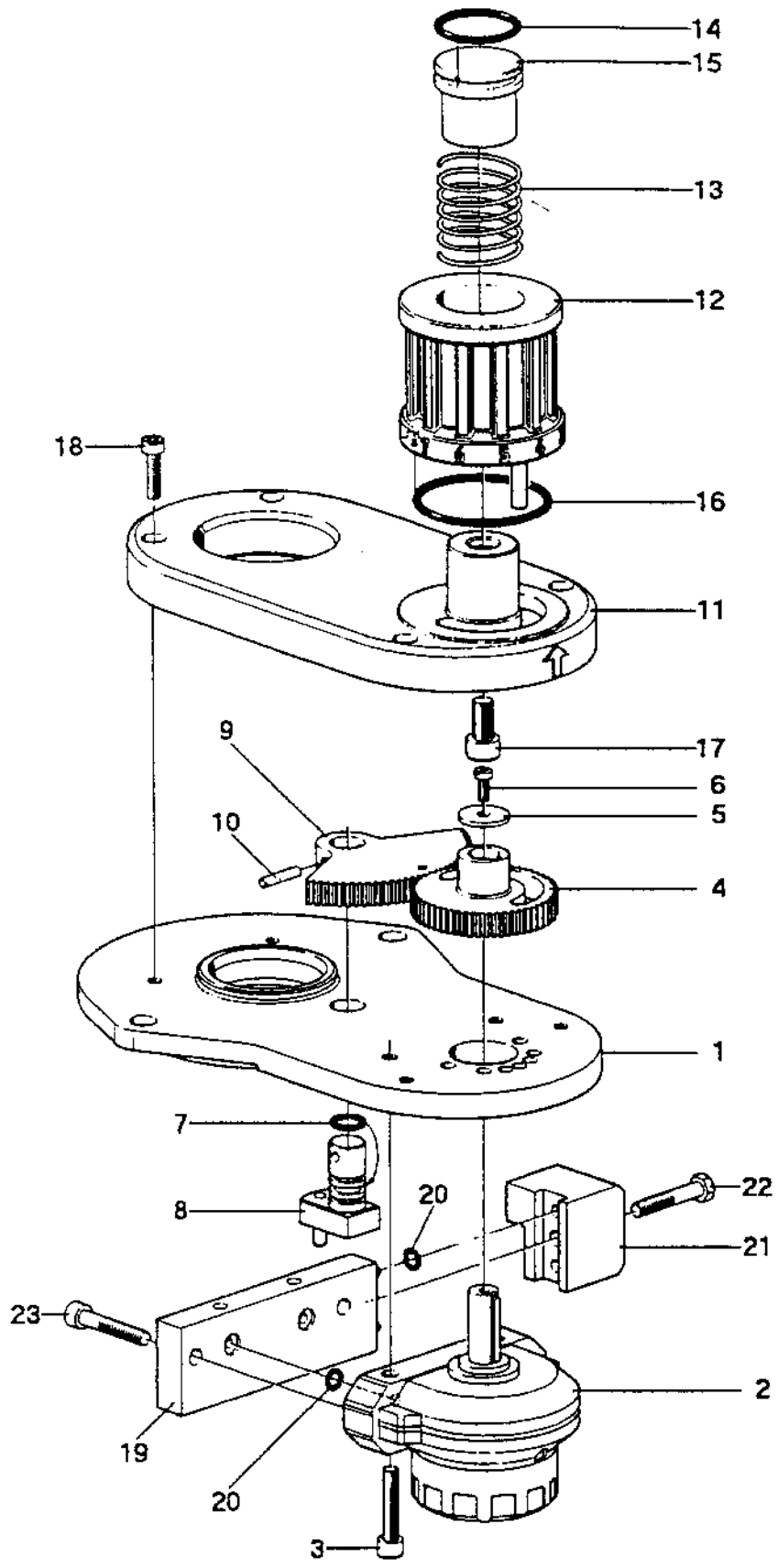

C-01228-0-3

|                                      |   |
|--------------------------------------|---|
| Machine type<br><b>PX 90VGV-15CY</b> | Machine unit description<br><b>Outlet device</b>          |
|                                      | Subassembly description<br><b>Cover with turning unit</b> |

|                         |
|-------------------------|
| Page<br><b>040-1.1</b>  |
| Fig. ref<br>C-01228-0-3 |
| Date<br>94-12           |

| Ref. | Part No   | Description              | Machine unit No. or<br>Subassembly description / Qty |  |  |  |  |  |  | Notes |
|------|-----------|--------------------------|--|--|--|--|--|--|--|-------|
|      |           |                          | 555212 -   |  |  |  |  |  |  |       |
|      |           |                          | - 82   |  |  |  |  |  |  |       |
| 1    | 555886 02 | Cover .....              | 1  |  |  |  |  |  |  |       |
| 2    | 554998 01 | Rotary acuator .....     | 1  |  |  |  |  |  |  |       |
| 3    | 221711 24 | Screw .....              | 2  |  |  |  |  |  |  |       |
| 4    | 555216 01 | Spur gear .....          | 1  |  |  |  |  |  |  |       |
| 5    | 554994 01 | Washer .....             | 1  |  |  |  |  |  |  |       |
| 6    | 71276     | Screw .....              | 1  |  |  |  |  |  |  |       |
| 7    | 223404 14 | O-ring .....             | 1  |  |  |  |  |  |  |       |
| 8    | 554991 80 | Turning stud .....       | 1  |  |  |  |  |  |  |       |
| 9    | 554993 01 | Tooth segment .....      | 1  |  |  |  |  |  |  |       |
| 10   | 222111 05 | Cylindrical pin .....    | 1  |  |  |  |  |  |  |       |
| 11   | 555218 02 | Casing .....             | 1  |  |  |  |  |  |  |       |
| 12   | 555213 81 | Knob .....               | 1  |  |  |  |  |  |  |       |
| 13   | 260083 34 | Compression spring ..... | 1  |  |  |  |  |  |  |       |
| 14   | 223406 26 | O-ring .....             | 1  |  |  |  |  |  |  |       |
| 15   | 555214 01 | Plug .....               | 1  |  |  |  |  |  |  |       |
| 16   | 223406 32 | O-ring .....             | 1  |  |  |  |  |  |  |       |
| 17   | 221716 16 | Screw .....              | 1  |  |  |  |  |  |  |       |
| 18   | 221706 13 | Screw .....              | 4  |  |  |  |  |  |  |       |
| 19   | 555307 80 | Coupling block .....     | 1  |  |  |  |  |  |  |       |
| 20   | 223404 05 | O-ring .....             | 4  |  |  |  |  |  |  |       |
| 21   | 555306 01 | Coupling piece .....     | 1  |  |  |  |  |  |  |       |
| 22   | 221031 07 | Screw .....              | 1  |  |  |  |  |  |  |       |
| 23   | 221711 25 | Screw .....              | 2  |  |  |  |  |  |  |       |

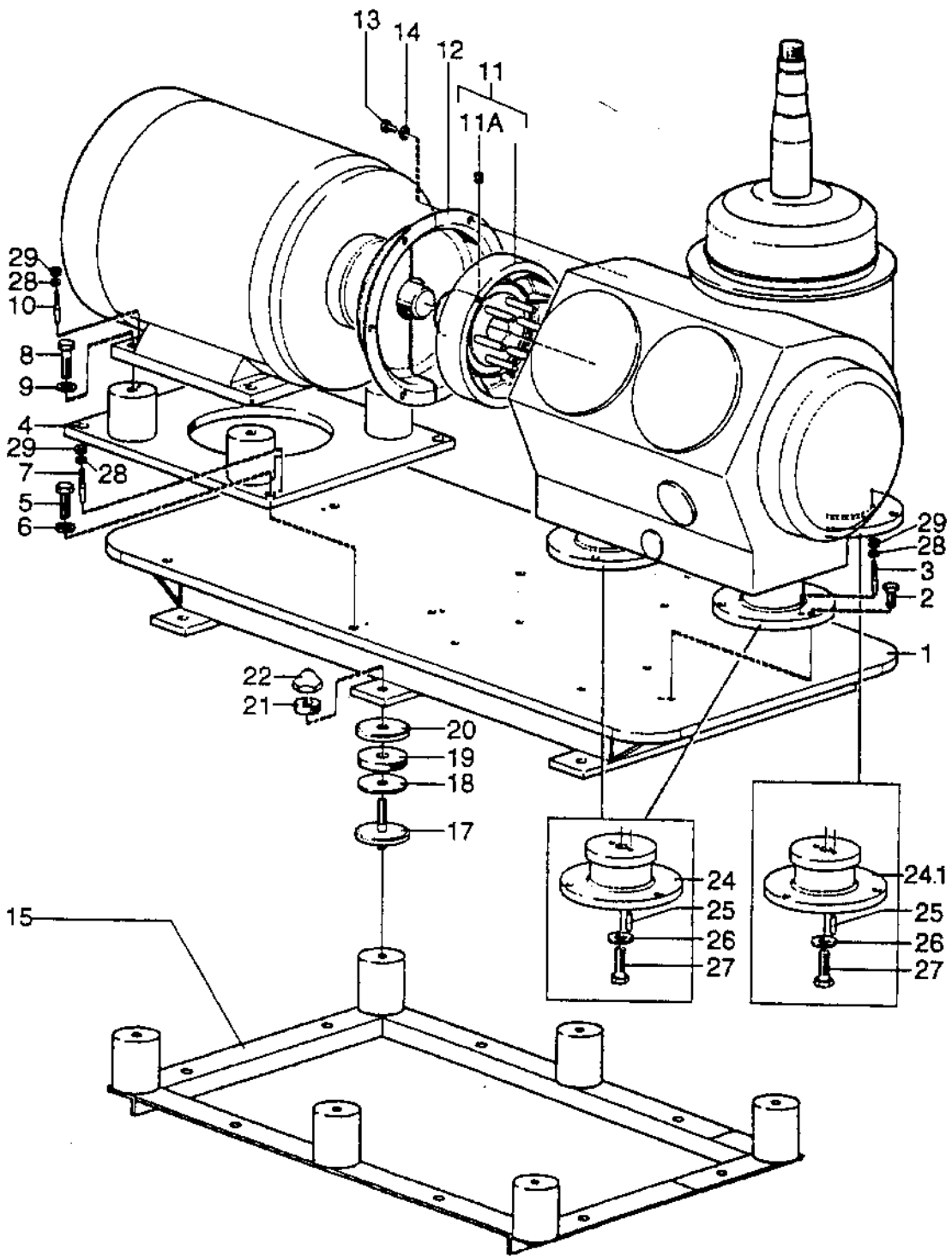

C-0085-1

|                                      |   |
|--------------------------------------|---|
| Machine type<br><b>PX 90VGV-15CY</b> | Machine unit description<br><b>Parts for motor mounting</b> |
|                                      | Subassembly description                                     |

|                         |
|-------------------------|
| Page<br><b>050-1</b>    |
| Fig. ref<br>C-00585-I-1 |
| Date<br>94-12           |

| Ref.  | Part No     | Description                     | Machine unit No. or<br>Subassembly description / Qty<br>545430 - |  |  |  |  |  |  | Notes |
|-------|-------------|---------------------------------|--|--|--|--|--|--|--|-------|
|       |             |                                 | - 08   |  |  |  |  |  |  |       |
| 1     | 525509 80   | Foundation plate .....          | 1  |  |  |  |  |  |  |       |
| 2     | 2 210462 10 | Screw .....                     | 9  |  |  |  |  |  |  |       |
| 3     | 222208 91   | Taper pin w. threaded end ..... | 2  |  |  |  |  |  |  |       |
| 4     | 555638 80   | Motor foundation .....          | 1  |  |  |  |  |  |  |       |
| 5     | 260001 01   | Screw .....                     | 4  |  |  |  |  |  |  |       |
| 6     | 223101 52   | Washer .....                    | 4  |  |  |  |  |  |  |       |
| 7     | 222208 91   | Taper pin w. threaded end ..... | 2  |  |  |  |  |  |  |       |
| 8     | 260001 20   | Screw .....                     | 4  |  |  |  |  |  |  |       |
| 9     | 223101 52   | Washer .....                    | 4  |  |  |  |  |  |  |       |
| 10    | 222208 94   | Taper pin w threaded end .....  | 2  |  |  |  |  |  |  |       |
| 11    | 544782 85   | Brake pulley .....              | 1  |  |  |  |  |  |  |       |
| 11A   | 221581 74   | Screw .....                     | 1  |  |  |  |  |  |  |       |
| 12    | 546149 02   | Guard .....                     | 1  |  |  |  |  |  |  |       |
| 13    | 221045 02   | Screw .....                     | 6  |  |  |  |  |  |  |       |
| 14    | 223101 49   | Washer .....                    | 6  |  |  |  |  |  |  |       |
| 15    | 556194 80   | Foundation, complete .....      | 1  |  |  |  |  |  |  |       |
| 17    | 419595 80   | Anchor bolt .....               | 6  |  |  |  |  |  |  |       |
| 18    | 71077       | Height adjusting washer .....   | 6  |  |  |  |  |  |  |       |
| 19    | 65232       | Rectangular ring .....          | 6  |  |  |  |  |  |  |       |
| 20    | 65233       | Cap .....                       | 6  |  |  |  |  |  |  |       |
| 21    | 65235       | Rectangular ring .....          | 6  |  |  |  |  |  |  |       |
| 22    | 419596 01   | Cap nut .....                   | 6  |  |  |  |  |  |  |       |
| 24    | 537681 03   | Frame foot .....                | 2  |  |  |  |  |  |  |       |
| 24.1  | 553187 02   | Frame foot .....                | 1  |  |  |  |  |  |  |       |
| 24.1A | 537681 03   | Frame foot .....                | 1  |  |  |  |  |  |  |       |
| 25    | 222111 18   | Parallel pin .....              | 6  |  |  |  |  |  |  |       |
| 26    | 223142 04   | Washer .....                    | 3  |  |  |  |  |  |  |       |
| 27    | 260001 17   | Screw .....                     | 3  |  |  |  |  |  |  |       |
| 28    | 41456       | Washer .....                    | 6  |  |  |  |  |  |  |       |
| 29    | 221803 29   | Nut .....                       | 6  |  |  |  |  |  |  |       |

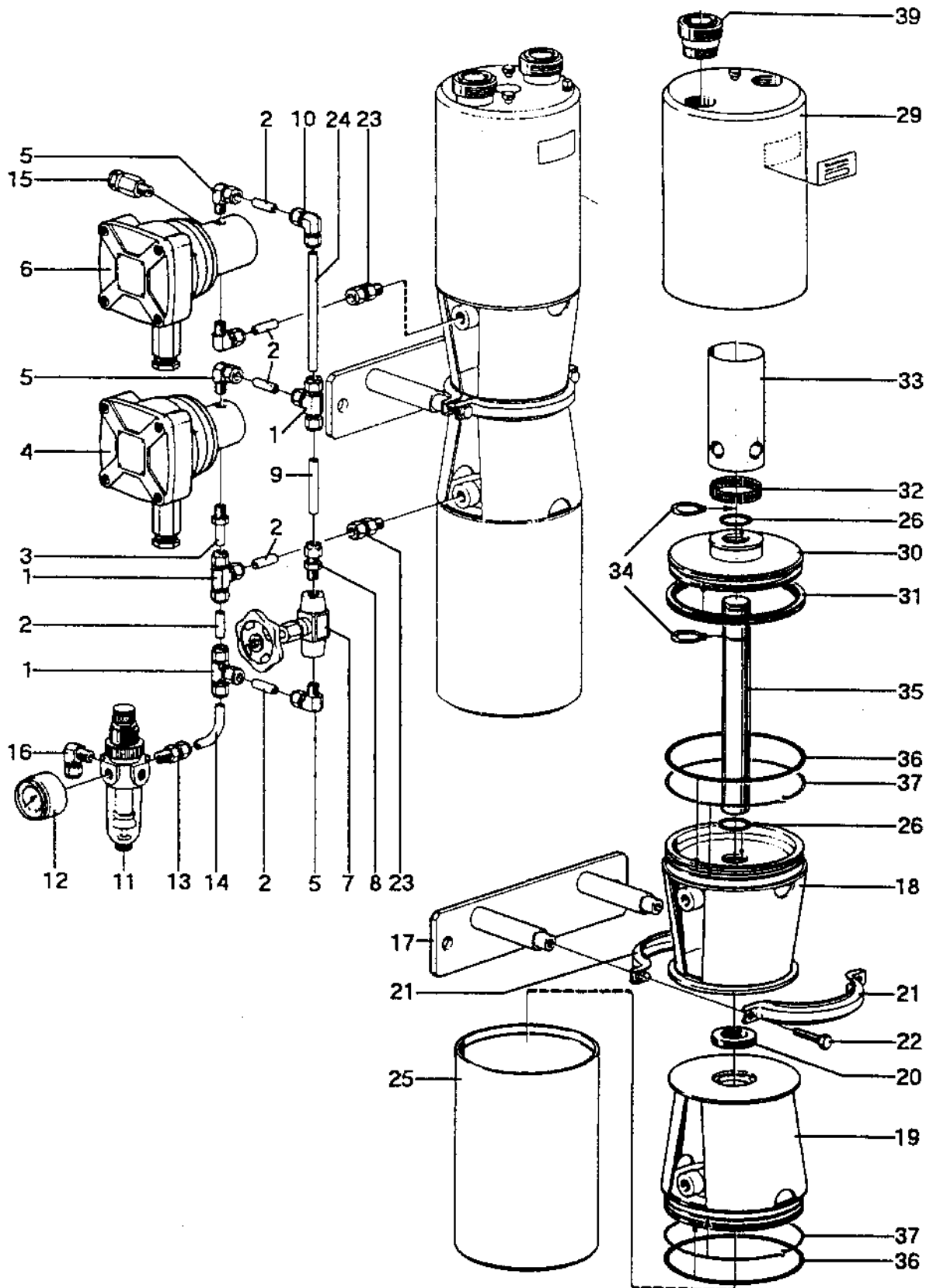

C-00017-1-4

|                                      |   |
|--------------------------------------|---|
| Machine type<br><b>PX 90VGV-15CY</b> | Machine unit description<br><b>Owm-twin 240 exd</b> |
|                                      | Subassembly description                             |

|                         |
|-------------------------|
| Page<br><b>060-1</b>    |
| Fig. ref<br>C-00017-1-6 |
| Date<br>94-12           |

| Ref. | Part No   | Description                     | Machine unit No or Subassembly description / Qty<br>554570 - |      |      |      |    |    |    |    | Notes            |
|------|-----------|---------------------------------|--|------|------|------|----|----|----|----|------------------|
|      |           |                                 | - 01   | - 02 | - 03 | - 04 |    |    |    |    |                  |
| 1    | 552894 13 | Union tee .....                 | 3  | 3    | 3    | 3    |    |    |    |    |                  |
| 2    | 552894 32 | Port connector .....            | 6  | 6    | 6    | 6    |    |    |    |    |                  |
| 3    | 552755 13 | Tube adapter .....              | 1  | 1    | 1    | 1    |    |    |    |    |                  |
| 4    | 554729 01 | Solenoid valve 24vdc exd .....  | 1  |      |      |      |    |    |    |    |                  |
| 5    | 552755 73 | Male elbow connector .....      | 4  | 4    | 4    | 4    |    |    |    |    |                  |
| 6    | 552652 70 | Solenoid valve 24vdc exd .....  | 1  | --   | --   | --   | -- | -- | -- | -- | 24 VDC           |
| 6    | 552652 71 | Solenoid valve 24vac exd .....  | --   | 1    | --   | --   | -- | -- | -- | -- | 24 VAC 50/60 Hz  |
| 6    | 552652 72 | Solenoid valve 48vac exd .....  | --   | --   | 1    | --   | -- | -- | -- | -- | 48 VAC 50/60 Hz  |
| 6    | 552652 73 | Solenoid valve 110vac exd ..... | --   | --   | --   | 1    | -- | -- | -- | -- | 110 VAC 50/60 Hz |
| 7    | 554038 01 | Needle valve .....              | 1  | 1    | 1    | 1    |    |    |    |    |                  |
| 8    | 552755 43 | Male connector .....            | 1  | 1    | 1    | 1    |    |    |    |    |                  |
| 9    | 554069 02 | Pipe .....                      | 1  | 1    | 1    | 1    |    |    |    |    |                  |
| 10   | 552894 02 | Union elbow .....               | 1  | 1    | 1    | 1    |    |    |    |    |                  |
| 11   | 770120 05 | Filter regulator .....          | 1  | 1    | 1    | 1    |    |    |    |    |                  |
| 12   | 543054 20 | Pressure gauge .....            | 1  | 1    | 1    | 1    |    |    |    |    |                  |
| 13   | 552755 32 | Male connector .....            | 1  | 1    | 1    | 1    |    |    |    |    |                  |
| 14   | 554068 03 | Elbow pipe .....                | 1  | 1    | 1    | 1    |    |    |    |    |                  |
| 15   | 553325 02 | Silencer .....                  | 1  | 1    | 1    | 1    |    |    |    |    |                  |
| 16   | 552755 60 | Male elbow connector .....      | 1  | 1    | 1    | 1    |    |    |    |    |                  |
| 17   | 544968 82 | Holder .....                    | 1  | 1    | 1    | 1    |    |    |    |    |                  |
| 18   | 554712 01 | Intermediate part .....         | 1  | 1    | 1    | 1    |    |    |    |    |                  |
| 19   | 554713 01 | Intermediate part .....         | 1  | 1    | 1    | 1    |    |    |    |    |                  |
| 20   | 545098 02 | Washer .....                    | 1  | 1    | 1    | 1    |    |    |    |    |                  |
| 21   | 544611 01 | Clamp half .....                | 2  | 2    | 2    | 2    |    |    |    |    |                  |
| 22   | 221036 06 | Screw .....                     | 2  | 2    | 2    | 2    |    |    |    |    |                  |
| 23   | 552755 33 | Male connector .....            | 2  | 2    | 2    | 2    |    |    |    |    |                  |
| 24   | 554069 07 | Pipe .....                      | 1  | 1    | 1    | 1    |    |    |    |    |                  |
| 25   | 555752 01 | Cylinder .....                  | 1  | 1    | 1    | 1    |    |    |    |    |                  |
| 26   | 223406 49 | O-ring .....                    | 2  | 2    | 2    | 2    |    |    |    |    |                  |
| 29   | 555751 01 | Cylinder .....                  | 1  | 1    | 1    | 1    |    |    |    |    |                  |
| 30   | 554065 01 | Piston .....                    | 1  | 1    | 1    | 1    |    |    |    |    |                  |
| 31   | 554090 02 | Piston seal .....               | 1  | 1    | 1    | 1    |    |    |    |    |                  |
| 32   | 554094 01 | Tolerance ring .....            | 1  | 1    | 1    | 1    |    |    |    |    |                  |
| 33   | 554059 01 | Distance pipe .....             | 1  | 1    | 1    | 1    |    |    |    |    |                  |
| 34   | 519975 05 | Snap ring .....                 | 2  | 2    | 2    | 2    |    |    |    |    |                  |
| 35   | 544590 01 | Piston rod .....                | 1  | 1    | 1    | 1    |    |    |    |    |                  |
| 36   | 223406 17 | O-ring .....                    | 2  | 2    | 2    | 2    |    |    |    |    |                  |
| 37   | 552835 02 | Locking wire .....              | 2  | 2    | 2    | 2    |    |    |    |    |                  |
| 39   | 544587 01 | Nipple .....                    | 2  | 2    | 2    | 2    |    |    |    |    |                  |

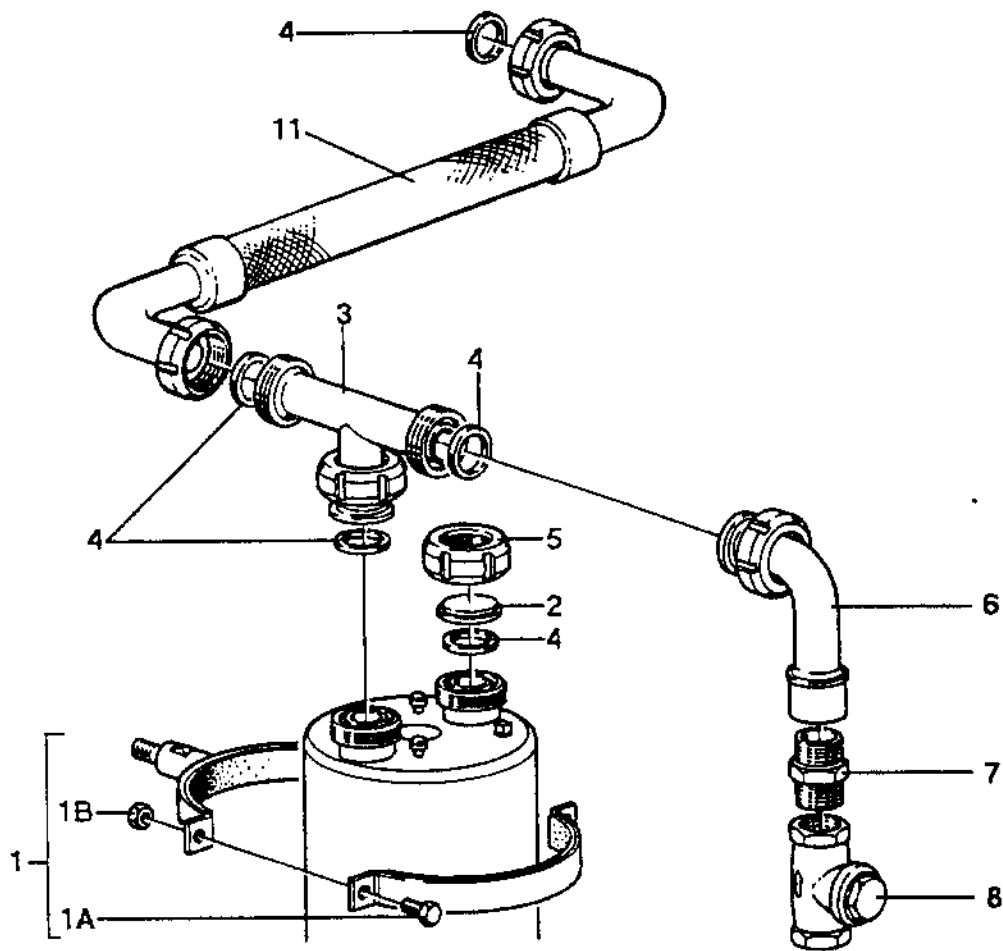

C-00018-1-3

|                                      |   |
|--------------------------------------|---|
| Machine type<br><b>PX 90VGV-15CY</b> | Machine unit description<br><b>Fittings for owm</b> |
|                                      | Subassembly description                             |

|                         |
|-------------------------|
| Page<br><b>070-1</b>    |
| Fig. ref<br>C-00016-1-3 |
| Date<br>94-12           |

| Ref. | Part No   | Description            | Machine unit No or Subassembly description / Qty<br>554906 - |  |  |  |  |  |  |  |  |  | Notes |  |  |
|------|-----------|------------------------|--|--|--|--|--|--|--|--|--|--|-------|--|--|
|      |           |                        | - 81   |  |  |  |  |  |  |  |  |  |       |  |  |
| 1    | 545113 80 | Support .....          | 1  |  |  |  |  |  |  |  |  |  |       |  |  |
| 1A   | 221036 01 | Screw .....            | 2  |  |  |  |  |  |  |  |  |  |       |  |  |
| 1B   | 221803 21 | Nut .....              | 2  |  |  |  |  |  |  |  |  |  |       |  |  |
| 2    | 190084    | Blind washer .....     | 1  |  |  |  |  |  |  |  |  |  |       |  |  |
| 3    | 544592 81 | T-piece .....          | 1  |  |  |  |  |  |  |  |  |  |       |  |  |
| 4    | 190601    | Rectangular ring ..... | 5  |  |  |  |  |  |  |  |  |  |       |  |  |
| 5    | 190613    | Coupling nut .....     | 1  |  |  |  |  |  |  |  |  |  |       |  |  |
| 6    | 544593 80 | Elbow pipe .....       | 1  |  |  |  |  |  |  |  |  |  |       |  |  |
| 7    | 543953 02 | Nipple .....           | 1  |  |  |  |  |  |  |  |  |  |       |  |  |
| 8    | 550675 01 | Check valve .....      | 1  |  |  |  |  |  |  |  |  |  |       |  |  |
| 11   | 554871 80 | Flexible hose .....    | 1  |  |  |  |  |  |  |  |  |  |       |  |  |

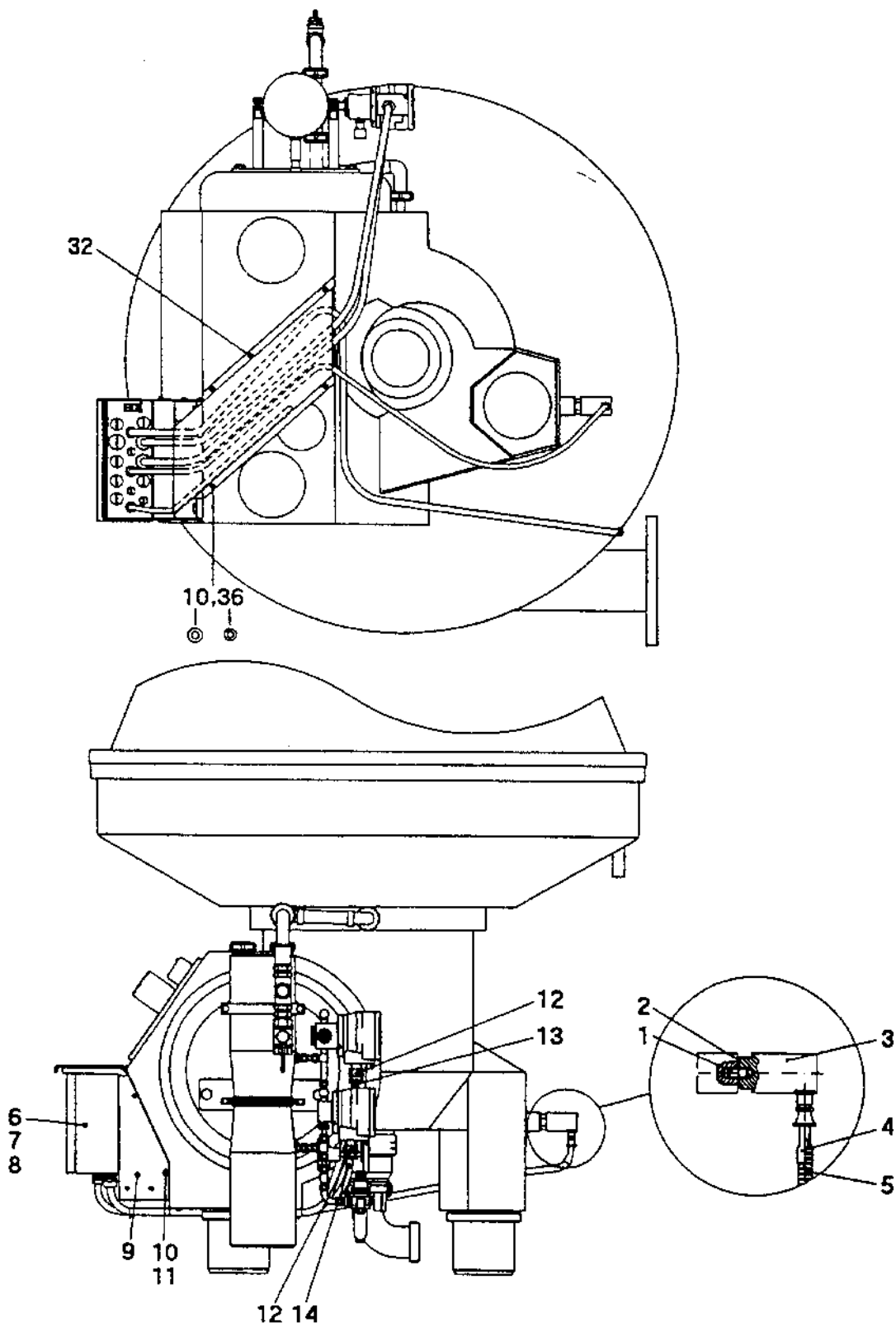

C-01188-04

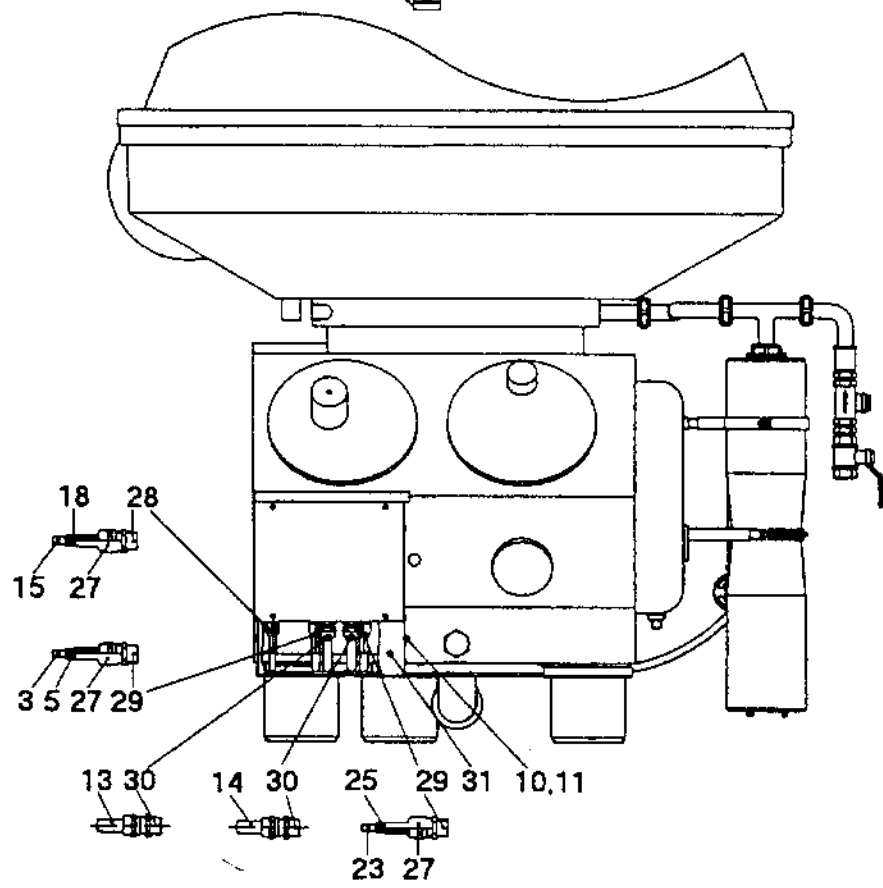
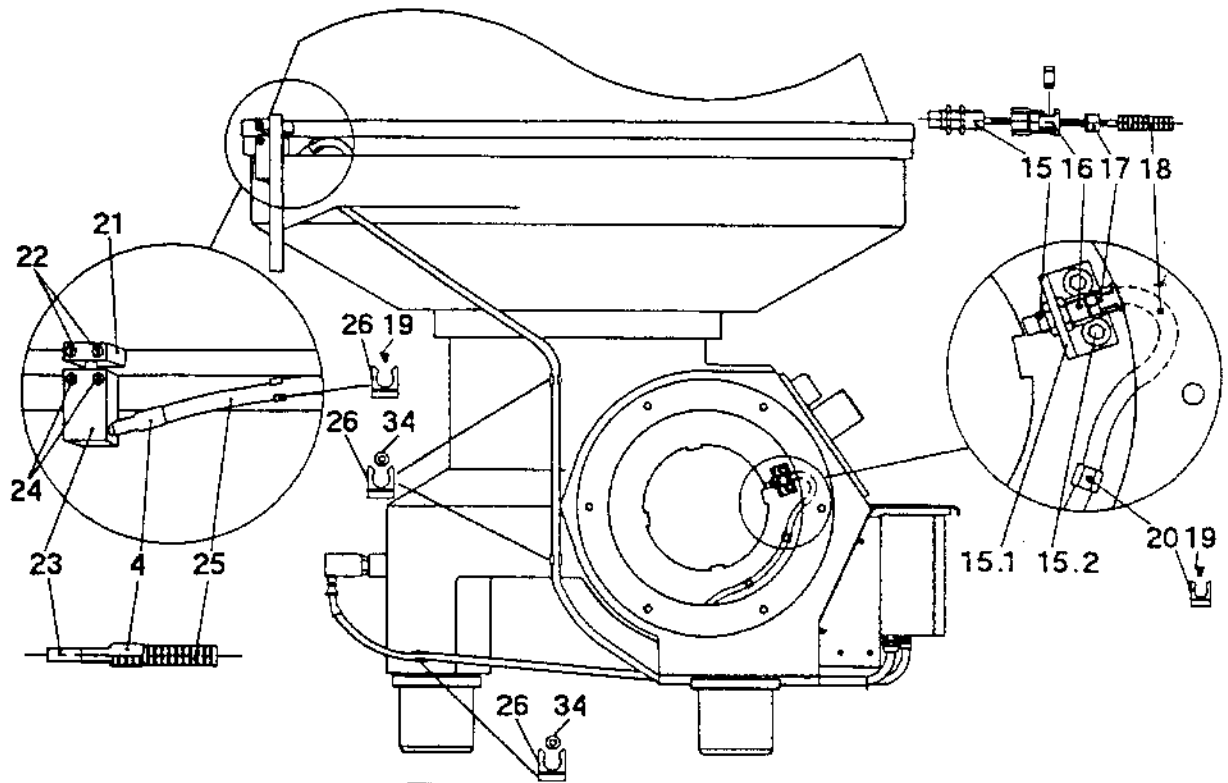

C-01180-0-7

|                                      |  |
|--------------------------------------|--|
| Machine type<br><b>PX 90VGV-15CY</b> | Machine unit description<br><b>Monitoring kit ex</b> |
|                                      | Subassembly description                              |

|                           |
|---------------------------|
| Page<br><b>080-1</b>      |
| Fig. ref<br>C-01160-0-6 + |
| Date<br>94-12             |

| Ref. | Part No   | Description                 | Machine unit No or Subassembly description / Qty |    |    |    |    |    |    |                  | Notes |
|------|-----------|-----------------------------|--|----|----|----|----|----|----|------------------|-------|
|      |           |                             | 555226 -   |    |    |    |    |    |    |                  |       |
|      |           |                             | -01  |    |    |    |    |    |    |                  |       |
| 1    | 260080 15 | Screw.....                  | 1  |    |    |    |    |    |    |                  |       |
| 2    | 223132 04 | Washer.....                 | 2  |    |    |    |    |    |    |                  |       |
| 3    | 547386 01 | Vibration sensor exd.....   | 1  |    |    |    |    |    |    |                  |       |
| 4    | 554627 01 | Insulating tube.....        | 2  |    |    |    |    |    |    |                  |       |
| 5    | 556416 04 | Protective tube.....        | 1  |    |    |    |    |    |    |                  |       |
| 6    | 555232 80 | Junction box ex.....        | 1  | -- | -- | -- | -- | -- | -- |                  |       |
| 7    | 552593 07 | Lock washer.....            | 4  |    |    |    |    |    |    | See page 080-1.1 |       |
| 8    | 221031 21 | Screw.....                  | 4  |    |    |    |    |    |    |                  |       |
| 9    | 555229 80 | Mounting plate.....         | 1  |    |    |    |    |    |    |                  |       |
| 10   | 552593 06 | Lock washer.....            | 12   |    |    |    |    |    |    |                  |       |
| 11   | 221706 20 | Screw.....                  | 8  |    |    |    |    |    |    |                  |       |
| 12   | 554047 47 | Cable gland.....            | 2  |    |    |    |    |    |    |                  |       |
| 13   | 556570 01 | Cable exd application.....  | 1  |    |    |    |    |    |    |                  |       |
| 14   | 556571 01 | Cable exd application.....  | 1  |    |    |    |    |    |    |                  |       |
| 15   | 552042 01 | Inductive sensor.....       | 1  |    |    |    |    |    |    |                  |       |
| 15.1 | 548367 02 | Holder.....                 | 1  |    |    |    |    |    |    |                  |       |
| 15.2 | 221041 26 | Screw.....                  | 2  |    |    |    |    |    |    |                  |       |
| 16   | 552870 90 | Tube adapter, straight..... | 1  |    |    |    |    |    |    |                  |       |
| 17   | 552870 61 | Compression gland.....      | 1  |    |    |    |    |    |    |                  |       |
| 18   | 556416 01 | Protective tube.....        | 1  |    |    |    |    |    |    |                  |       |
| 19   | 221121 46 | Screw.....                  | 3  |    |    |    |    |    |    |                  |       |
| 20   | 552869 93 | Tube clip.....              | 2  |    |    |    |    |    |    |                  |       |
| 21   | 553261 01 | Switch actuator.....        | 1  |    |    |    |    |    |    |                  |       |
| 22   | 221126 09 | Screw.....                  | 2  |    |    |    |    |    |    |                  |       |
| 23   | 551337 01 | Limit switch.....           | 1  |    |    |    |    |    |    |                  |       |
| 24   | 221121 15 | Screw.....                  | 2  |    |    |    |    |    |    |                  |       |
| 25   | 556416 06 | Protective tube.....        | 1  |    |    |    |    |    |    |                  |       |
| 26   | 552869 94 | Tube clip.....              | 6  |    |    |    |    |    |    |                  |       |
| 27   | 554627 02 | Insulating tube.....        | 3  |    |    |    |    |    |    |                  |       |
| 28   | 551897 11 | Cable gland blue.....       | 1  |    |    |    |    |    |    |                  |       |
| 29   | 555603 02 | Cable gland brass.....      | 2  |    |    |    |    |    |    |                  |       |
| 30   | 555603 05 | Cable gland brass.....      | 2  |    |    |    |    |    |    |                  |       |
| 31   | 555230 01 | Cable cover.....            | 1  |    |    |    |    |    |    |                  |       |
| 32   | 555298 01 | Cable holder.....           | 1  |    |    |    |    |    |    |                  |       |
| 34   | 221803 26 | Nut.....                    | 5  |    |    |    |    |    |    |                  |       |
| 36   | 221803 27 | Nut.....                    | 4  |    |    |    |    |    |    |                  |       |

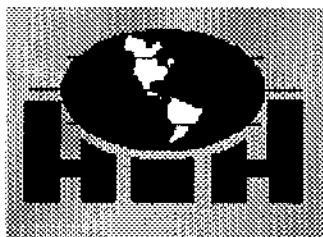

## **Hutchison-Hayes Separators, Inc.**

**This is a Spacer Page**

**P.O. Box 2965 ♦ Houston, Texas 77252**  
**3520 East Belt ♦ Houston, Texas 77015**  
**(713) 455-9600 ♦ Fax (713) 455-7753**

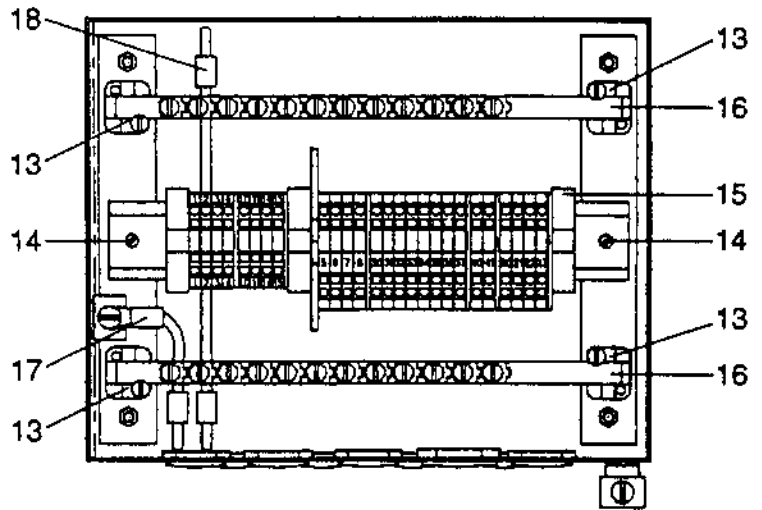
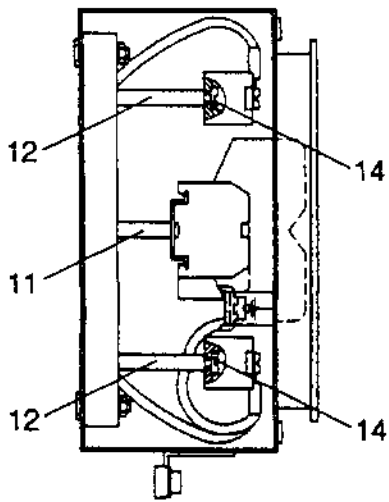
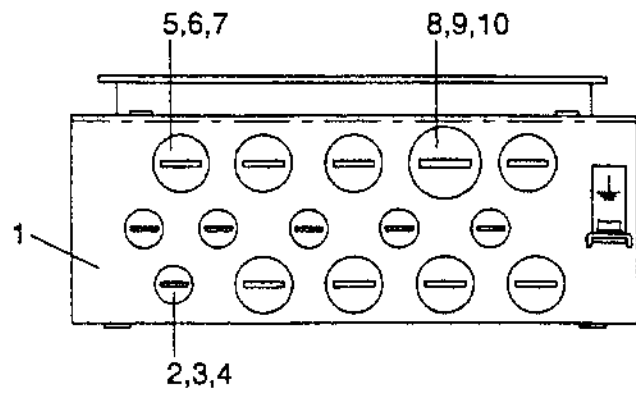

C-01212-04

|                               |   |
|-------------------------------|---|
| Machine type<br>PX 90VGV-15CY | Machine unit description<br>Monitoring kit ex |
|                               | Subassembly description<br>Junction box ex    |

|                         |
|-------------------------|
| Page<br><b>080-1.1</b>  |
| Fig. ref<br>C-01212-0-6 |
| Date<br>94-12           |

| Ref. | Part No   | Description             | Machine unit No or Subassembly description / Qty<br>555232 - |  |  |  |  |  |  | Notes |
|------|-----------|-------------------------|--|--|--|--|--|--|--|-------|
|      |           |                         | - 80   |  |  |  |  |  |  |       |
| 1    | 555233 01 | Box exxa, drilled ..... | 1  |  |  |  |  |  |  |       |
| 2    | 552851 32 | Stopping plug .....     | 6  |  |  |  |  |  |  |       |
| 3    | 223403 01 | O-ring .....            | 6  |  |  |  |  |  |  |       |
| 4    | 552851 22 | Lock nut .....          | 6  |  |  |  |  |  |  |       |
| 5    | 552851 35 | Stopping plug .....     | 8  |  |  |  |  |  |  |       |
| 6    | 223403 17 | O-ring .....            | 8  |  |  |  |  |  |  |       |
| 7    | 552851 25 | Lock nut .....          | 8  |  |  |  |  |  |  |       |
| 8    | 552851 36 | Stopping plug .....     | 1  |  |  |  |  |  |  |       |
| 9    | 223403 19 | O-ring .....            | 1  |  |  |  |  |  |  |       |
| 10   | 552851 26 | Lock nut .....          | 1  |  |  |  |  |  |  |       |
| 11   | 550532 47 | Distance screw .....    | 2  |  |  |  |  |  |  |       |
| 12   | 550532 50 | Distance screw .....    | 4  |  |  |  |  |  |  |       |
| 13   | 552830 50 | Support .....           | 4  |  |  |  |  |  |  |       |
| 14   | 221126 04 | Screw .....             | 6  |  |  |  |  |  |  |       |
| 15   | 555234 01 | Terminal row ex .....   | 1  |  |  |  |  |  |  |       |
| 16   | 550127 32 | Earth bar .....         | 2  |  |  |  |  |  |  |       |
| 17   | 552867 12 | Cable .....             | 1  |  |  |  |  |  |  |       |
| 18   | 552867 13 | Cable .....             | 1  |  |  |  |  |  |  |       |
| 19   | 539436 01 | Article no. plate ..... | 1  |  |  |  |  |  |  |       |

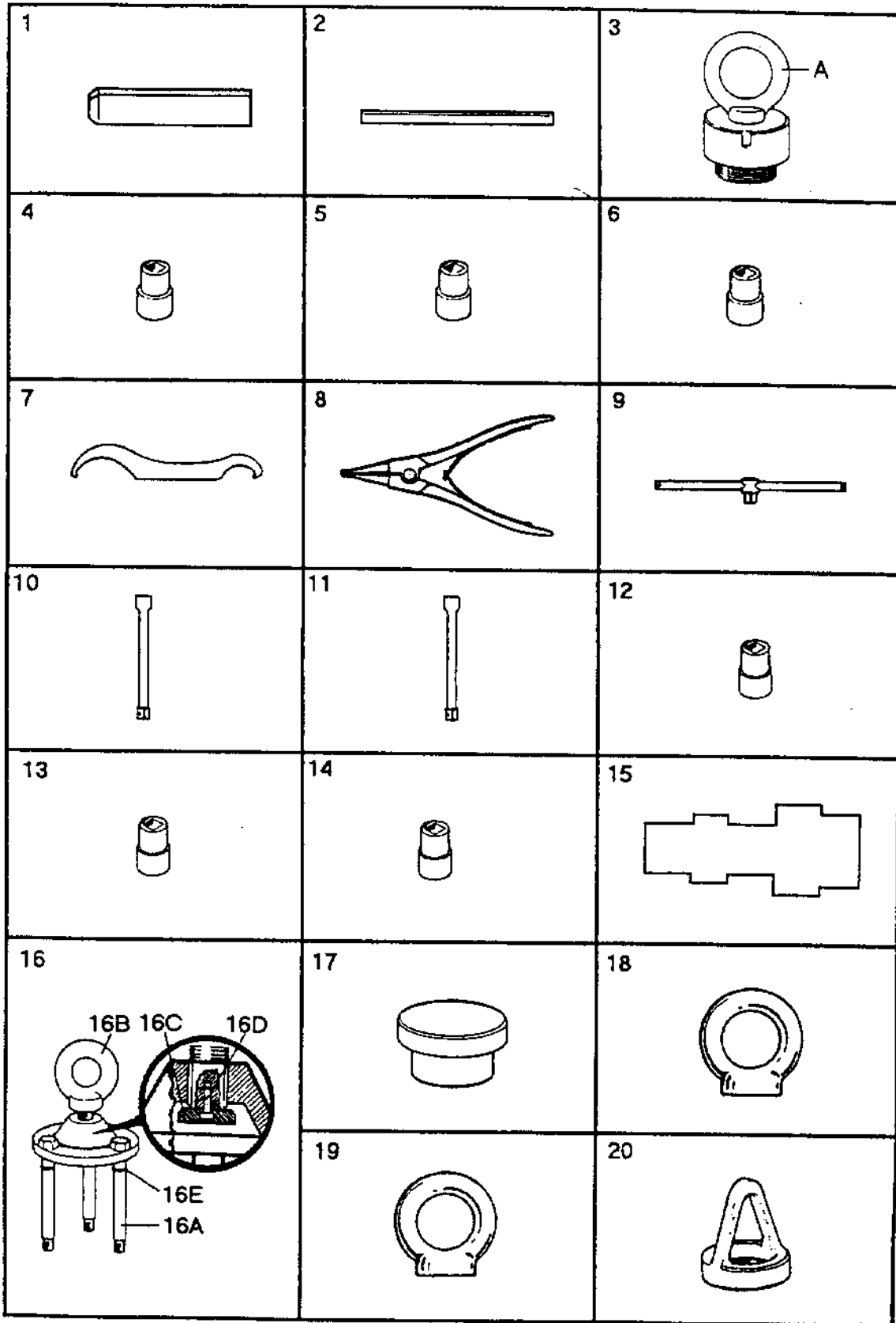

C-01173-B-1

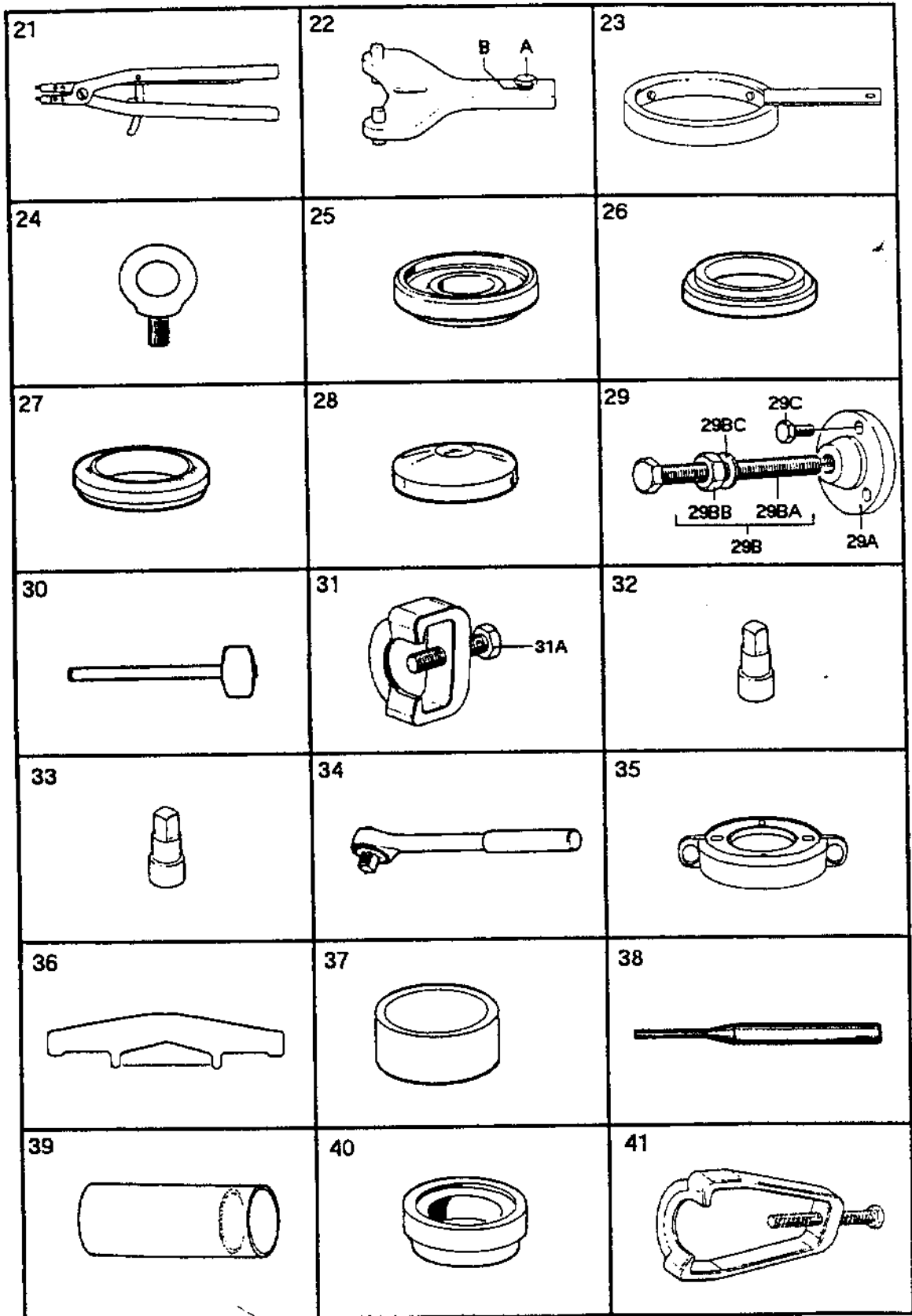

C-01172-T-1

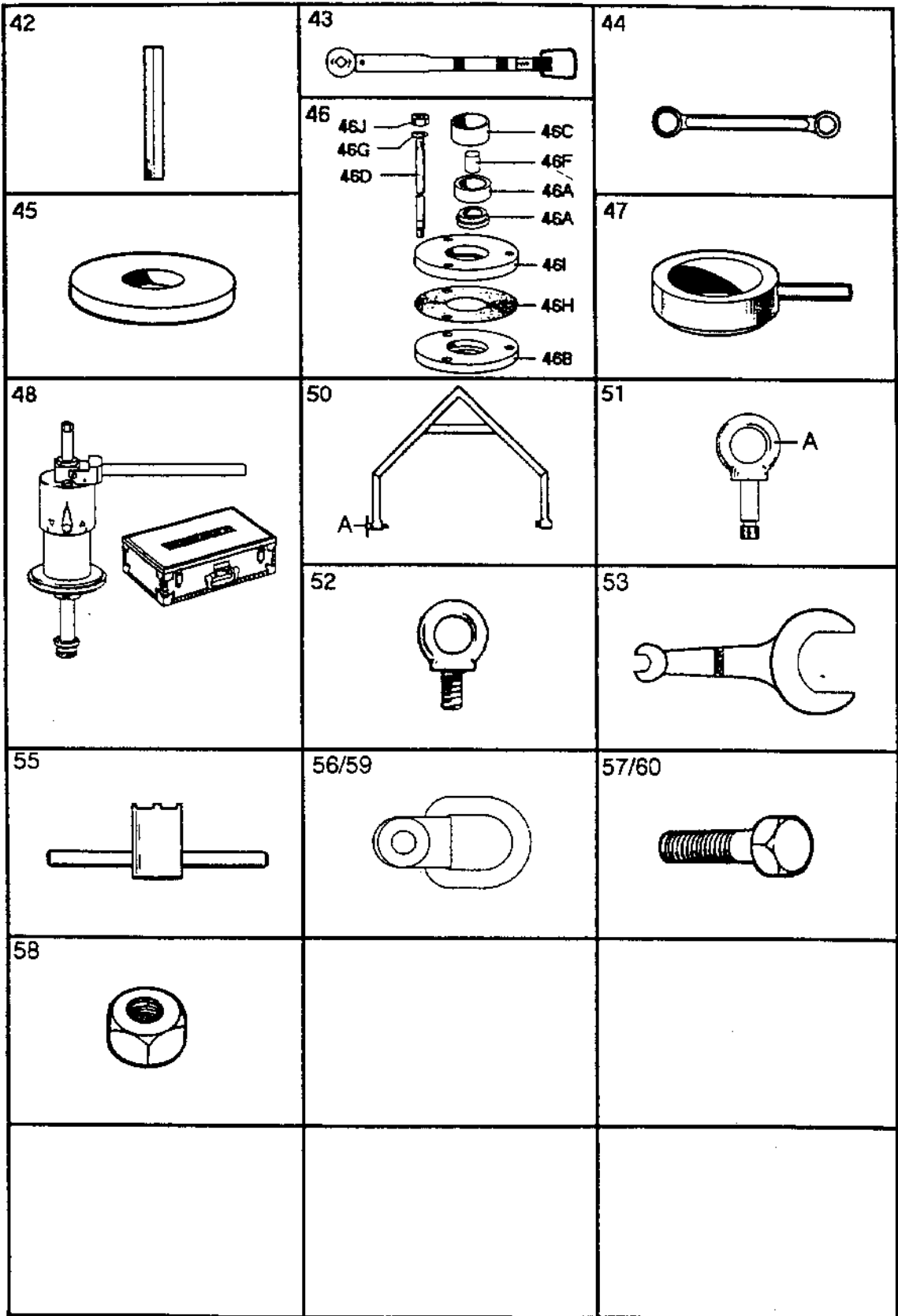

|                                      |   |
|--------------------------------------|---|
| Machine type<br><b>PX 90VGV-15CY</b> | Machine unit description<br><b>Set of tools</b> |
|                                      | Subassembly description                         |

|                             |
|-----------------------------|
| Page<br><b>090-1A</b>       |
| Fig. ref<br>C-01172-S-1 + + |
| Date<br>94-12               |

| Ref. | Part No     | Description                   | Machine unit No or Subassembly description / Qty<br>555535 - |    |    |    |    |    |    |    | Notes          |
|------|-------------|-------------------------------|--|----|----|----|----|----|----|----|----------------|
|      |             |                               | - 03   |    |    |    |    |    |    |    |                |
| 1    | 531296 82   | Driving-off tool .....        | 1  |    |    |    |    |    |    |    |                |
| 2    | 541647 02   | Dismounting drift.....        | 1  |    |    |    |    |    |    |    |                |
| 3    | 555518 80   | Lifting tool .....            | 1  |    |    |    |    |    |    |    |                |
| 3A   | 260154 03   | Lifting eye bolt.....         | 1  | -- | -- | -- | -- | -- | -- | -- | M20            |
| 4    | 72978       | Socket 11 mm (1/2") .....     | 1  | -- | -- | -- | -- | -- | -- | -- | 11 mm          |
| 5    | 527353 09   | Socket 30 mm (1/2") .....     | 1  | -- | -- | -- | -- | -- | -- | -- | 30 mm          |
| 6    | 527353 17   | Socket 16 mm (1/2") .....     | 1  | -- | -- | -- | -- | -- | -- | -- | 16 mm          |
| 7    | 68696       | Hook spanner .....            | 1  |    |    |    |    |    |    |    |                |
| 8    | 42386       | Mounting tongs .....          | 1  |    |    |    |    |    |    |    |                |
| 9    | 72243       | T-handle .....                | 1  |    |    |    |    |    |    |    |                |
| 10   | 72244       | Extension rod 255 mm.....     | 1  | -- | -- | -- | -- | -- | -- | -- | L = 255 mm     |
| 11   | 527348 01   | Extension rod 125-150 mm..... | 1  | -- | -- | -- | -- | -- | -- | -- | L = 125-150 mm |
| 12   | 527353 05   | Socket 18 mm (1/2") .....     | 1  | -- | -- | -- | -- | -- | -- | -- | 18 mm          |
| 13   | 73085       | Socket 24 mm (1/2") .....     | 1  | -- | -- | -- | -- | -- | -- | -- | 24 mm          |
| 14   | 75420       | Socket 13 mm (1/2") .....     | 1  | -- | -- | -- | -- | -- | -- | -- | 13 mm          |
| 15   | 548765 01   | Temple.....                   | 1  |    |    |    |    |    |    |    |                |
| 16   | 543307 80   | Lifting tool .....            | 1  |    |    |    |    |    |    |    |                |
| 16A  | 544088 01   | Screw .....                   | 3  |    |    |    |    |    |    |    |                |
| 16B  | 543309 01   | Lifting eye .....             | 1  |    |    |    |    |    |    |    |                |
| 16C  | 543310 01   | Washer .....                  | 1  |    |    |    |    |    |    |    |                |
| 16D  | 221711 02   | Screw .....                   | 1  |    |    |    |    |    |    |    |                |
| 16E  | 68372       | Snap ring .....               | 3  |    |    |    |    |    |    |    |                |
| 17   | 530313 03   | Plug .....                    | 1  |    |    |    |    |    |    |    |                |
| 18   | 540131 80   | Lifting tool .....            | 1  |    |    |    |    |    |    |    |                |
| 19   | 540131 82   | Lifting tool .....            | 1  | -- | -- | -- | -- | -- | -- | -- | M42X1,5        |
| 20   | 545532 80   | Lifting tool .....            | 1  |    |    |    |    |    |    |    |                |
| 21   | 66445       | Snap ring pliers (hole).....  | 1  |    |    |    |    |    |    |    |                |
| 22   | 543346 80   | Spanner .....                 | 1  |    |    |    |    |    |    |    |                |
| 22A  | 2 210462 55 | Screw .....                   | 1  |    |    |    |    |    |    |    |                |
| 22B  | 223101 37   | Washer .....                  | 1  |    |    |    |    |    |    |    |                |
| 23   | 554765 80   | Spanner for lock ring.....    | 1  |    |    |    |    |    |    |    |                |
| 24   | 260154 05   | Lifting eye bolt.....         | 2  | -- | -- | -- | -- | -- | -- | -- | M16            |
| 25   | 546855 01   | Ring .....                    | 1  |    |    |    |    |    |    |    |                |
| 26   | 543550 01   | Ring .....                    | 1  |    |    |    |    |    |    |    |                |
| 27   | 543551 01   | Ring .....                    | 1  |    |    |    |    |    |    |    |                |
| 28   | 543552 01   | Mounting tool .....           | 1  |    |    |    |    |    |    |    |                |
| 29   | 543553 80   | Dismounting tool.....         | 1  |    |    |    |    |    |    |    |                |
| 29A  | 543554 01   | Washer .....                  | 1  |    |    |    |    |    |    |    |                |
| 29B  | 537464 84   | Mounting tool .....           | 1  |    |    |    |    |    |    |    |                |
| 29BA | 260001 42   | Screw .....                   | 1  |    |    |    |    |    |    |    |                |
| 29BB | 544275 01   | Nut .....                     | 1  |    |    |    |    |    |    |    |                |
| 29BC | 223101 52   | Washer.....                   | 1  |    |    |    |    |    |    |    |                |
| 29C  | 221045 09   | Screw.....                    | 3  | -- | -- | -- | -- | -- | -- | -- | L=30mm         |
| 30   | 64324       | Tin hammer .....              | 1  |    |    |    |    |    |    |    |                |
| 31   | 545756 80   | Puller .....                  | 1  |    |    |    |    |    |    |    |                |
| 31A  | 280001 41   | Screw.....                    | 1  |    |    |    |    |    |    |    |                |
| 32   | 260164 03   | Hexagon socket spanner.....   | 1  | -- | -- | -- | -- | -- | -- | -- | 8 mm           |
| 33   | 260164 06   | Hexagon socket spanner.....   | 1  | -- | -- | -- | -- | -- | -- | -- | 14 mm          |
| 34   | 260161 01   | Ratchet handle .....          | 1  |    |    |    |    |    |    |    |                |
| 35   | 556513 80   | Lifting tool .....            | 1  |    |    |    |    |    |    |    |                |
| 36   | 544284 01   | Pressure washer.....          | 1  |    |    |    |    |    |    |    |                |
| 37   | 544273 01   | Sleeve.....                   | 1  |    |    |    |    |    |    |    |                |
| 38   | 544372 01   | Drift .....                   | 1  |    |    |    |    |    |    |    |                |
| 39   | 544288 01   | Tube .....                    | 1  |    |    |    |    |    |    |    |                |

|                              |  |                             |
|------------------------------|--|-----------------------------|
| Machine type<br>PX 90VG-15CY | Machine unit description<br>Set of tools | Page<br>090-1B              |
|                              | Subassembly description                  | Fig. ref<br>C-01172-S-1 + + |
|                              |  | Date<br>94-12               |

| Ref. | Part No     | Description                   | Machine unit No. or<br>Subassembly description / Qty<br>555535 - |    |    |    |    |    |    |           | Notes |
|------|-------------|-------------------------------|--|----|----|----|----|----|----|-----------|-------|
|      |             |                               | - 03   |    |    |    |    |    |    |           |       |
| 40   | 544261 01   | Ring .....                    | 1  |    |    |    |    |    |    |           |       |
| 41   | 544302 02   | Puller .....                  | 1  |    |    |    |    |    |    |           |       |
| 42   | 521196 16   | Socket spanner .....          | 1  | -- | -- | -- | -- | -- | -- | 36 mm     |       |
| 43   | 544371 01   | Torque wrench .....           | 1  |    |    |    |    |    |    |           |       |
| 44   | 528905 08   | Ring spanner .....            | 1  |    |    |    |    |    |    |           |       |
| 45   | 537441 01   | Washer .....                  | 1  |    |    |    |    |    |    |           |       |
| 46   | 545540 80   | Mount and dismount tool ..... | 1  |    |    |    |    |    |    |           |       |
| 46A  | 545547 01   | Ring .....                    | 1  |    |    |    |    |    |    |           |       |
| 46B  | 545541 01   | Plate lower .....             | 1  |    |    |    |    |    |    |           |       |
| 46C  | 545546 01   | Sleeve .....                  | 1  |    |    |    |    |    |    |           |       |
| 46D  | 545544 01   | Bar .....                     | 3  |    |    |    |    |    |    |           |       |
| 46E  | 545545 01   | Support ring .....            | 1  |    |    |    |    |    |    |           |       |
| 46F  | 545548 01   | Intermediate part .....       | 1  |    |    |    |    |    |    |           |       |
| 46G  | 68372       | Snap ring .....               | 3  |    |    |    |    |    |    |           |       |
| 46H  | 545543 01   | Washer .....                  | 1  |    |    |    |    |    |    |           |       |
| 46I  | 545542 01   | Plate upper .....             | 1  |    |    |    |    |    |    |           |       |
| 46J  | 221803 35   | Nut .....                     | 3  | -- | -- | -- | -- | -- | -- | M20       |       |
| 47   | 545529 80   | Pin spanner .....             | 1  |    |    |    |    |    |    |           |       |
| 48   | 549790 06   | Compression tool .....        | 1  |    |    |    |    |    |    |           |       |
| 50   | 555368 81   | Turning tool bowl body .....  | 1  |    |    |    |    |    |    |           |       |
| 51   | 555522 80   | Lifting tool .....            | 1  |    |    |    |    |    |    |           |       |
| 52   | 542118 80   | Lifting eye .....             | 2  |    |    |    |    |    |    |           |       |
| 53   | 65454       | Screw spanner .....           | 1  | -- | -- | -- | -- | -- | -- | 55 + 15mm |       |
| 55   | 555511 80   | Mounting tool .....           | 1  |    |    |    |    |    |    |           |       |
| 56   | 553188 01   | Lifting eye .....             | 1  |    |    |    |    |    |    |           |       |
| 57   | 260001 22   | Screw .....                   | 1  | -- | -- | -- | -- | -- | -- | M20       |       |
| 58   | 221803 35   | Nut .....                     | 1  | -- | -- | -- | -- | -- | -- | M20       |       |
| 59   | 553188 02   | Lifting eye .....             | 2  |    |    |    |    |    |    |           |       |
| 60   | 2 210463 06 | Screw .....                   | 2  |    |    |    |    |    |    |           |       |

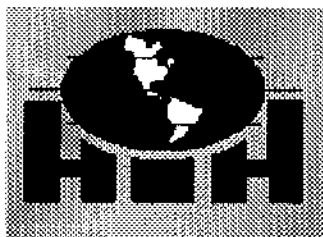

## **Hutchison-Hayes Separators, Inc.**

**This is a Spacer Page**

**P.O. Box 2965 ♦ Houston, Texas 77252**  
**3520 East Belt ♦ Houston, Texas 77015**  
**(713) 455-9600 ♦ Fax (713) 455-7753**

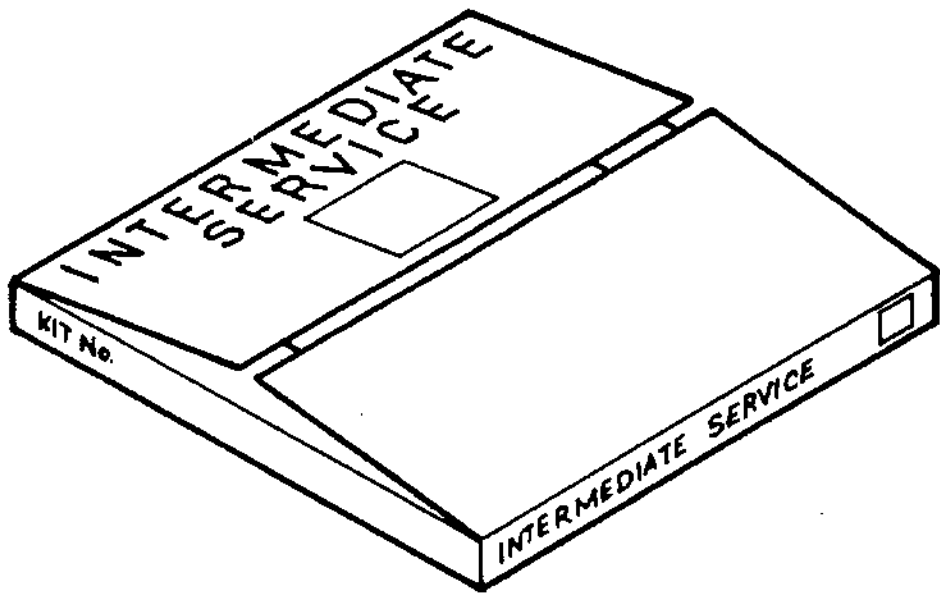

C-0770-0-1

Machine type

PX 90VGV-15CY

Intermediate service kit

Subassembly description

100-1

Fig. ref  
C-00780-0-1Date  
94-12

| Ref. | Part No   | Description             | Machine unit No or<br>Subassembly description / Qty<br>554083 - |  |  |  |  |  |  | Notes |
|------|-----------|-------------------------|---|--|--|--|--|--|--|-------|
|      |           |                         | - 02  |  |  |  |  |  |  |       |
| 1    | 543343 01 | Gasket .....            | 1   |  |  |  |  |  |  |       |
| 2    | 543422 02 | Rectangular ring .....  | 1   |  |  |  |  |  |  |       |
| 3    | 537838 06 | Valve plug .....        | 3   |  |  |  |  |  |  |       |
| 4    | 523116 04 | Rectangular ring .....  | 1   |  |  |  |  |  |  |       |
| 5    | 223416 35 | O-ring .....            | 1   |  |  |  |  |  |  |       |
| 6    | 223406 64 | O-ring .....            | 1   |  |  |  |  |  |  |       |
| 7    | 223406 58 | O-ring .....            | 1   |  |  |  |  |  |  |       |
| 8    | 521863 02 | Rectangular ring .....  | 1   |  |  |  |  |  |  |       |
| 9    | 543170 01 | Seal ring .....         | 1   |  |  |  |  |  |  |       |
| 10   | 74355     | O-ring .....            | 1   |  |  |  |  |  |  |       |
| 11   | 223412 06 | O-ring .....            | 1   |  |  |  |  |  |  |       |
| 12   | 223406 75 | O-ring .....            | 1   |  |  |  |  |  |  |       |
| 14   | 223412 06 | O-ring .....            | 1   |  |  |  |  |  |  |       |
| 15   | 223406 10 | O-ring .....            | 1   |  |  |  |  |  |  |       |
| 16   | 223412 52 | O-ring .....            | 1   |  |  |  |  |  |  |       |
| 17   | 223412 27 | O-ring .....            | 1   |  |  |  |  |  |  |       |
| 17.5 | 555123 01 | Bearing .....           | 2   |  |  |  |  |  |  |       |
| 18   | 223406 30 | O-ring .....            | 5   |  |  |  |  |  |  |       |
| 19   | 190604    | Rectangular ring .....  | 1   |  |  |  |  |  |  |       |
| 21   | 223406 15 | O-ring .....            | 1   |  |  |  |  |  |  |       |
| 22   | 223406 69 | O-ring .....            | 1   |  |  |  |  |  |  |       |
| 24   | 223406 58 | O-ring .....            | 1   |  |  |  |  |  |  |       |
| 25   | 260104 79 | O-ring .....            | 1   |  |  |  |  |  |  |       |
| 27   | 190605    | Rectangular ring .....  | 1   |  |  |  |  |  |  |       |
| 30   | 554236 81 | Seal ring .....         | 1   |  |  |  |  |  |  |       |
| 31   | 223316 05 | Rectangular ring .....  | 1   |  |  |  |  |  |  |       |
| 32   | 528732 03 | Packing .....           | 1   |  |  |  |  |  |  |       |
| 33   | 539474 03 | Silicone grease .....   | 1   |  |  |  |  |  |  | 25 g  |
| 34   | 554336 01 | Lubricating paste ..... | 1   |  |  |  |  |  |  |       |
| 35   | 74634     | O-ring .....            | 3   |  |  |  |  |  |  |       |

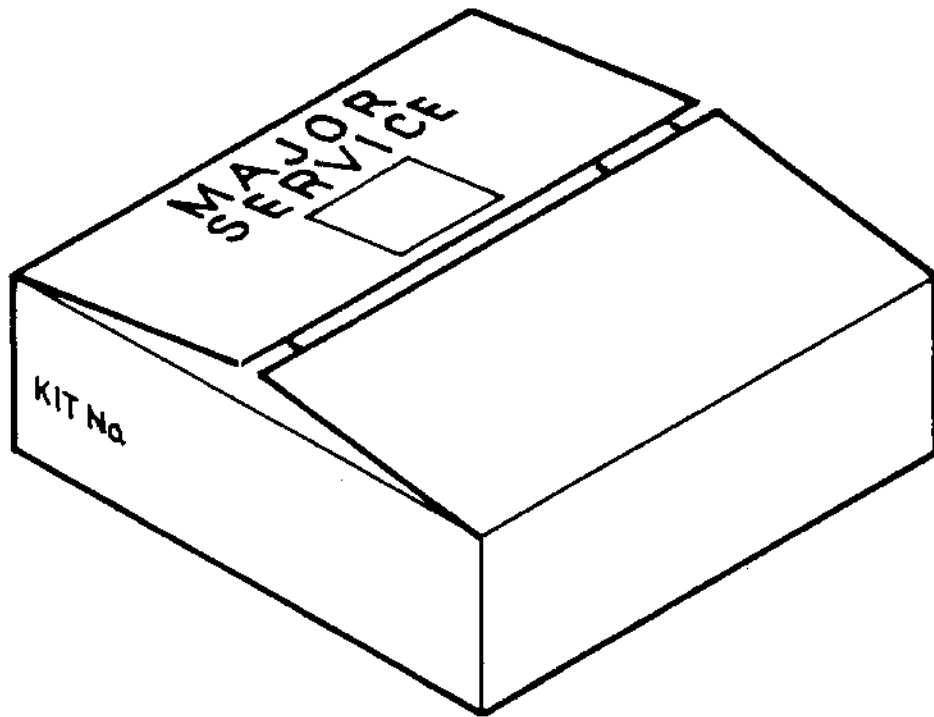

C-00781-0-1

|                              |   |
|------------------------------|---|
| Machine type<br>PX 90GV-15CY | Machine unit description<br>Major service kit |
|                              | Subassembly description                       |

|                         |
|-------------------------|
| Page<br>101-1           |
| Fig. ref<br>C-00781-0-1 |
| Date<br>94-12           |

| Ref. | Part No   | Description                 | Machine unit No or Subassembly description / Qty |  |  |  |  |  |  | Notes |
|------|-----------|-----------------------------|--|--|--|--|--|--|--|-------|
|      |           |                             | 554084 -   |  |  |  |  |  |  |       |
|      |           |                             | - 02   |  |  |  |  |  |  |       |
| 1    | 37167     | Rectangular ring .....      | 1  |  |  |  |  |  |  |       |
| 2    | 528723 01 | Gasket .....                | 1  |  |  |  |  |  |  |       |
| 3    | 73665     | Rectangular ring .....      | 2  |  |  |  |  |  |  |       |
| 4    | 545063 03 | Tolerance ring .....        | 1  |  |  |  |  |  |  |       |
| 5    | 43626     | Gasket .....                | 1  |  |  |  |  |  |  |       |
| 6    | 43630     | Seal strip .....            | 1  |  |  |  |  |  |  |       |
| 7    | 528732 03 | Packing .....               | 1  |  |  |  |  |  |  |       |
| 8    | 223406 17 | O-ring .....                | 1  |  |  |  |  |  |  |       |
| 9    | 548747 07 | Ball bearing .....          | 1  |  |  |  |  |  |  |       |
| 10   | 223642 49 | Snap ring .....             | 1  |  |  |  |  |  |  |       |
| 11   | 548745 04 | Ball bearing .....          | 1  |  |  |  |  |  |  |       |
| 12   | 223641 01 | Snap ring .....             | 1  |  |  |  |  |  |  |       |
| 13   | 529639 02 | Rubber buffer .....         | 2  |  |  |  |  |  |  |       |
| 14   | 541453 05 | Uslit ring .....            | 3  |  |  |  |  |  |  |       |
| 15   | 555231 01 | Seal ring .....             | 1  |  |  |  |  |  |  |       |
| 16   | 544271 01 | Seal ring .....             | 1  |  |  |  |  |  |  |       |
| 17   | 223412 18 | O-ring .....                | 1  |  |  |  |  |  |  |       |
| 18   | 548746 04 | Ball bearing .....          | 1  |  |  |  |  |  |  |       |
| 19   | 223406 36 | O-ring .....                | 1  |  |  |  |  |  |  |       |
| 20   | 233211 94 | Ball bearing .....          | 1  |  |  |  |  |  |  |       |
| 21   | 8379      | Ball bearing .....          | 1  |  |  |  |  |  |  |       |
| 22   | 60571     | Elastic plate .....         | 3  |  |  |  |  |  |  |       |
| 23   | 555245 01 | Height adjusting ring ..... | 5  |  |  |  |  |  |  |       |
| 23.1 | 260104 28 | O-ring .....                | 1  |  |  |  |  |  |  |       |
| 23.5 | 555453 01 | Gasket .....                | 1  |  |  |  |  |  |  |       |
| 24   | 547413 05 | Seal strip .....            | 1  |  |  |  |  |  |  |       |
| 25   | 223406 25 | O-ring .....                | 1  |  |  |  |  |  |  |       |
| 26   | 517774 34 | Gasket .....                | 1  |  |  |  |  |  |  |       |
| 27   | 190606    | Rectangular ring .....      | 5  |  |  |  |  |  |  |       |
| 28   | 190604    | Rectangular ring .....      | 2  |  |  |  |  |  |  |       |
| 29   | 547030 80 | Wear ring .....             | 1  |  |  |  |  |  |  |       |
| 29.1 | 223406 15 | O-ring .....                | 1  |  |  |  |  |  |  |       |
| 29.2 | 546635 01 | Radiation ring .....        | 1  |  |  |  |  |  |  |       |
| 30   | 553144 02 | Height adjusting ring ..... | 7  |  |  |  |  |  |  |       |
| 31   | 190601    | Rectangular ring .....      | 5  |  |  |  |  |  |  |       |
| 32   | 519975 05 | Snap ring .....             | 2  |  |  |  |  |  |  |       |
| 33   | 223406 17 | O-ring .....                | 2  |  |  |  |  |  |  |       |
| 34   | 223406 49 | O-ring .....                | 4  |  |  |  |  |  |  |       |
| 35   | 554090 02 | Piston seal .....           | 1  |  |  |  |  |  |  |       |

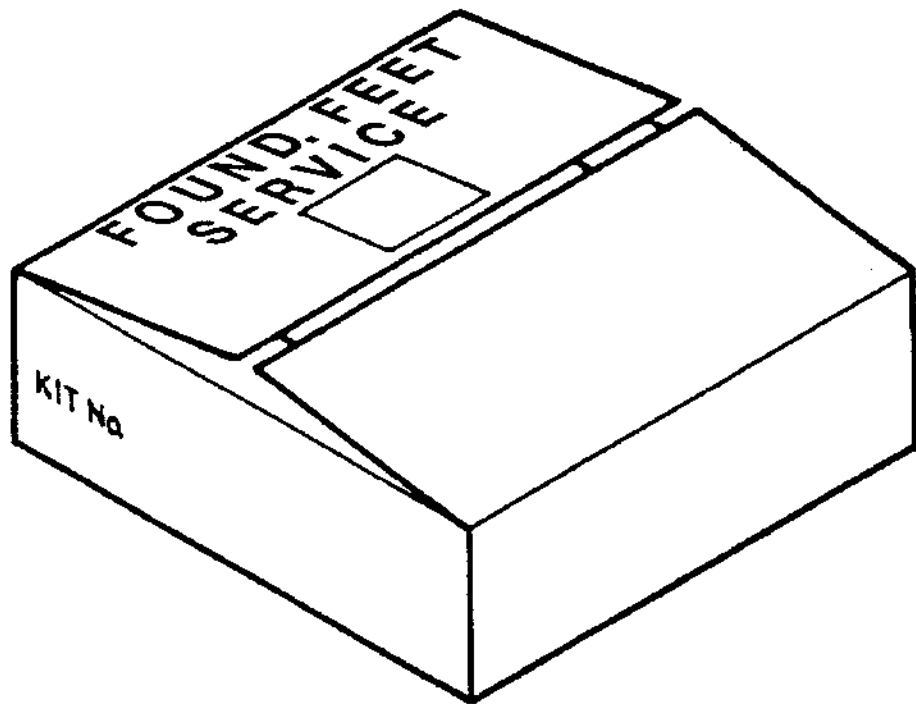

C-00781-03

|                               |   |
|-------------------------------|---|
| Machine type<br>PX 80VGV-15CY | Machine unit description<br>Service kit f. found feet |
|                               | Subassembly description                               |

|                         |
|-------------------------|
| Page<br>102-1           |
| Fig. ref<br>C-007B1-0-3 |
| Date<br>84-12           |

| Ref. | Part No | Description            | Machine unit No or<br>Subassembly description / Qty<br>548378 - |  |  |  |  |  |  | Notes |
|------|---------|------------------------|---|--|--|--|--|--|--|-------|
|      |         |                        | - 08  |  |  |  |  |  |  |       |
| 7    | 65235   | Rectangular ring ..... | 6   |  |  |  |  |  |  |       |
| 11   | 65232   | Rectangular ring ..... | 6   |  |  |  |  |  |  |       |
| 12   | 74309   | Screw.....             | 6   |  |  |  |  |  |  |       |

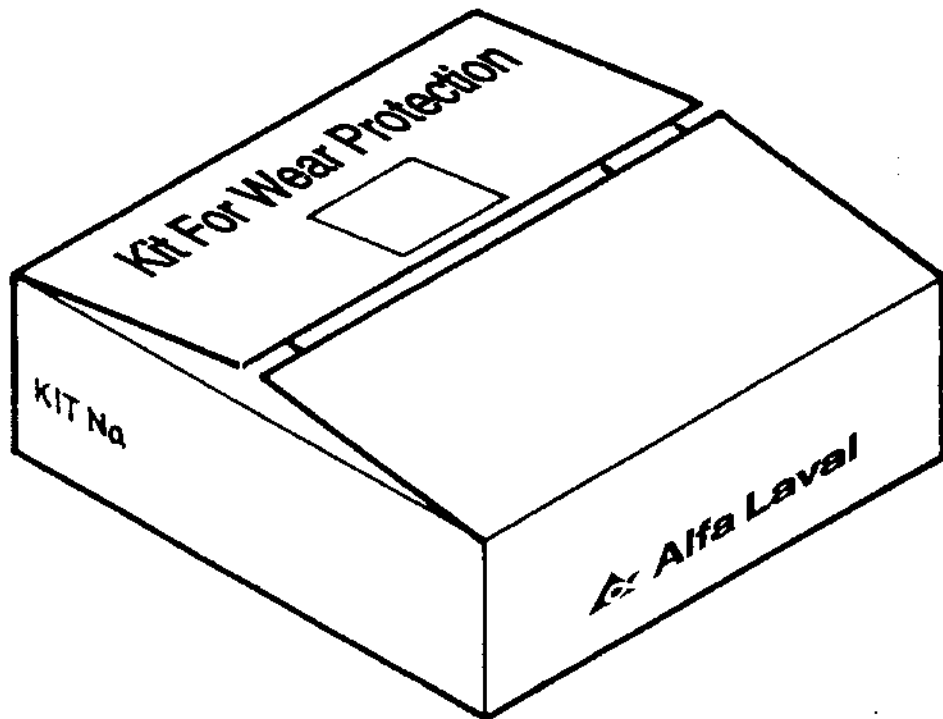

C-00781-1-1

|                                     |  |
|-------------------------------------|--|
| Machine type<br><b>PX 90GV-15CY</b> | Machine unit description<br><b>Kit for wear protection</b> |
|                                     | Subassembly description                                    |

|                         |
|-------------------------|
| Page<br><b>103-1</b>    |
| Fig. ref<br>C-00781-1-1 |
| Date<br>94-12           |

| Ref. | Part No   | Description           | Machine unit No or<br>Subassembly description / Qty<br>556169 - |  |  |  |  |  |  | Notes |
|------|-----------|-----------------------|---|--|--|--|--|--|--|-------|
|      |           |                       | - 01  |  |  |  |  |  |  |       |
| 1    | 549006 02 | Wear protection ..... | 12  |  |  |  |  |  |  |       |
| 2    | 549844 80 | Mounting tool .....   | 1   |  |  |  |  |  |  |       |
| 2A   | 543126 80 | Clamp screw .....     | 1   |  |  |  |  |  |  |       |