

Hutchison-Hayes Separators, Inc.

Model BRPX 213 SGV-10EFR Parts List With Diagrams

P.O. Box 2965 ♦ Houston, Texas 77252
3520 East Belt ♦ Houston, Texas 77015
(713) 455-9600 ♦ Fax (713) 455-7753

ALFA-LAVAL

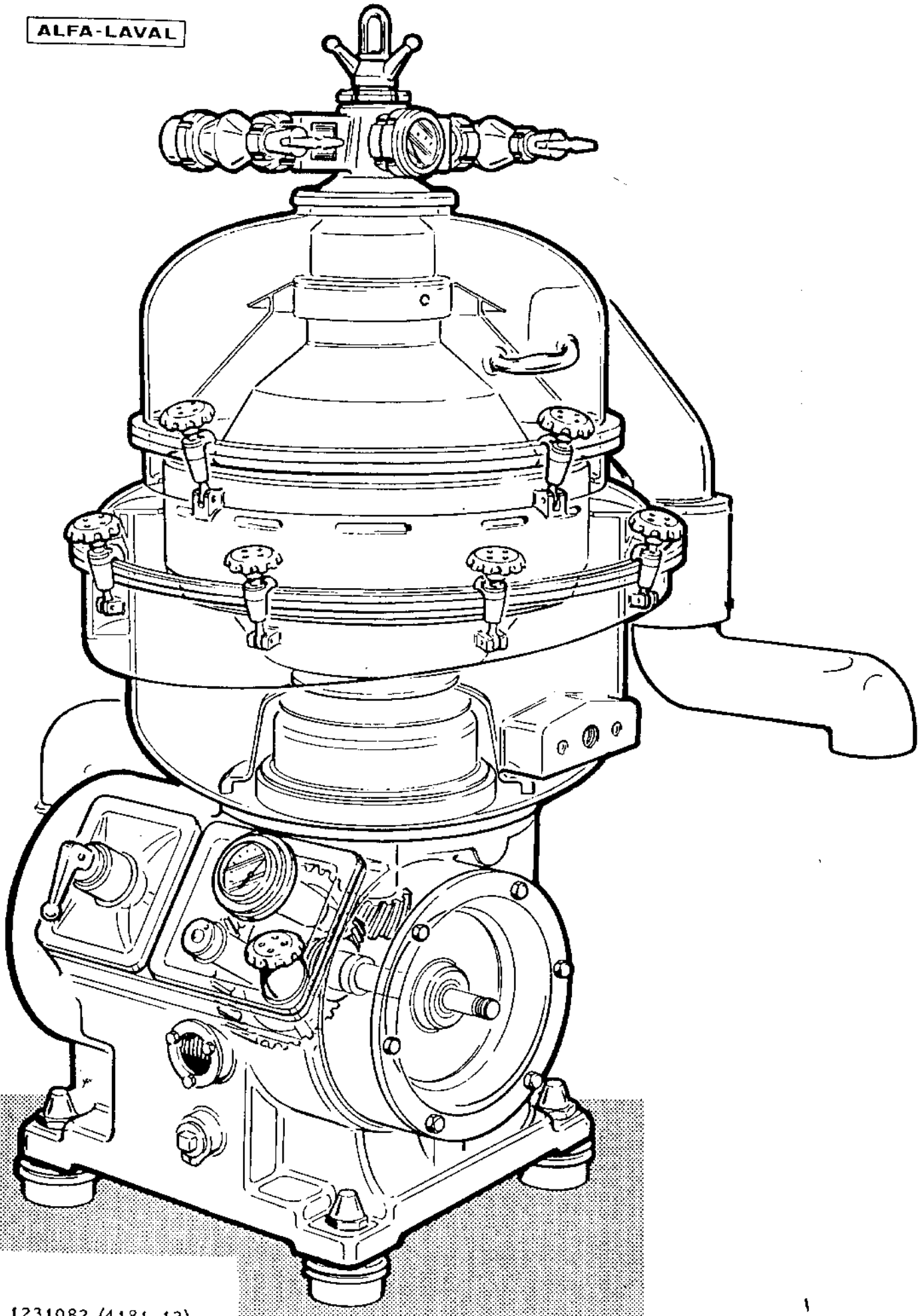

1231082 (4181-12)

(Bowl for TOTAL DISCHARGE, page 2)

Screw (8)
-- 72239

Spring support*
-- 74718

Spring (18)
-- 68657

Operating slide
-- 74716

Seal ring
-- 74355

Valve plug (3)
-- 71468

Bowl body*
-- 75079

Nozzle
-- 71433

* Exchange necessitates rebalancing -- send the COMPLETE bowl to an ALFA-LAVAL/DE LAVAL representative.

** Not included in the complete-unit number.

CLARIFIER BOWL with EROSION-PROTECTED SLIDING BOWL BOTTOM for TOTAL DISCHARGE -- 525730-85

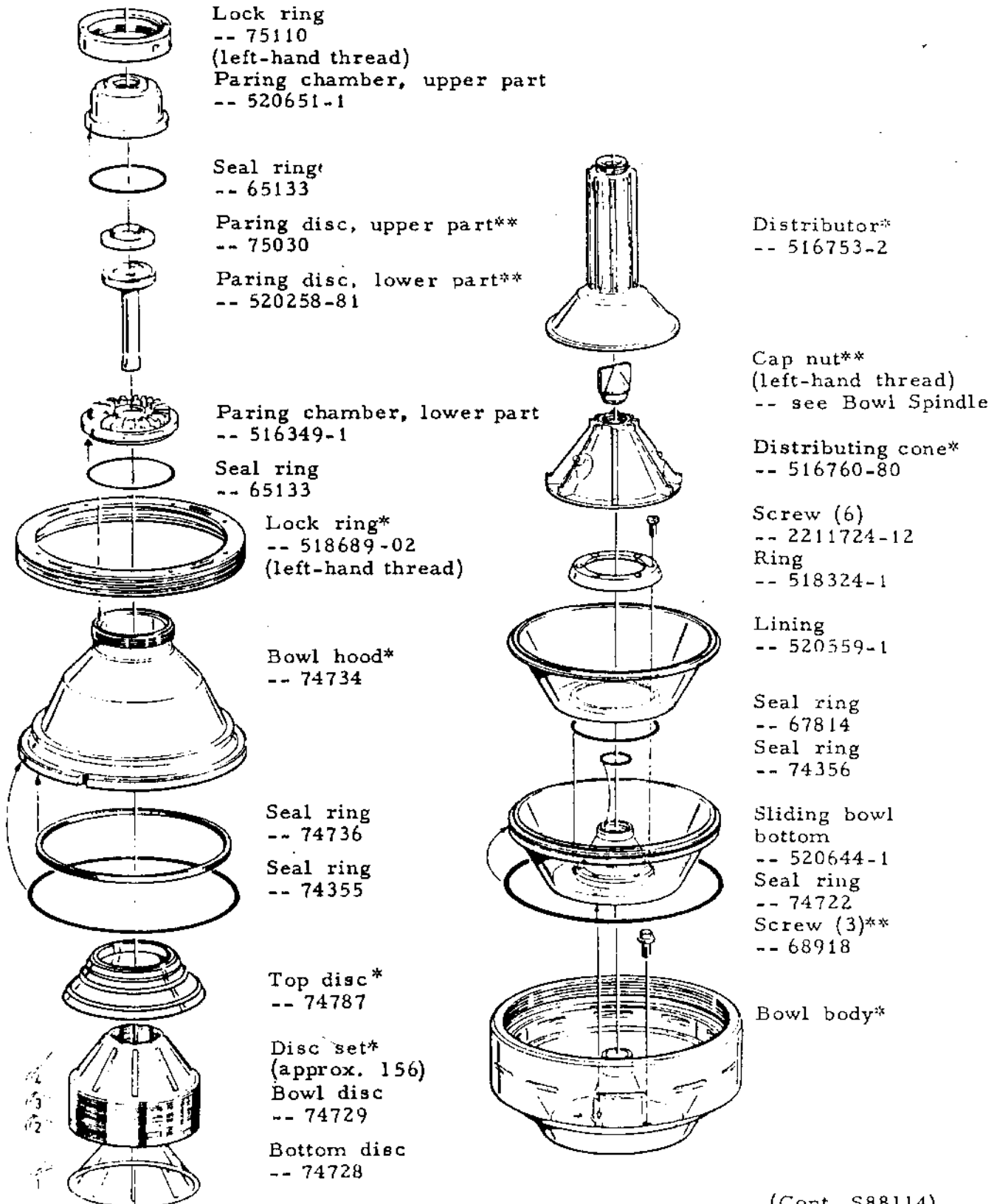

(Cont. S88114)

FRAME HOOD and PARTS MOUNTED ON IT

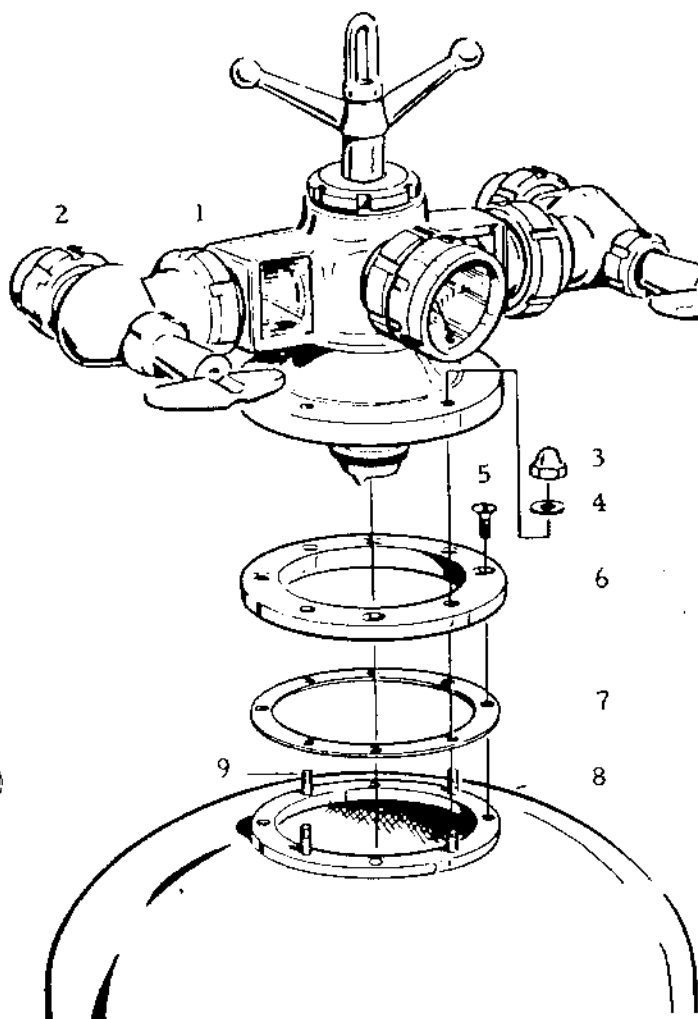

Parts list

- | | |
|---|-----------------------------|
| 1 | Connection housing |
| | -- see chapter X |
| 2 | Regulating valve (2) |
| | -- see chapter X |
| 3 | Cap nut (4) |
| | -- 72947 |
| 4 | Washer (4) |
| | --223101-34 |
| 5 | Screw (4) |
| | -- 2212608-3 |
| 6 | Guide ring |
| | -- 527971-1 |
| 7 | Height adjusting ring (1-7) |
| | -- 528096-1 |
| 8 | Frame hood |
| | -- 74790, 74753* |
| 9 | Stud bolt (4) |
| | -- 67912 |
- * For purifier and concentrator

Dismantling

Note that the bowl must come to rest before dismantling is commenced. To render the bowl accessible e.g. for cleaning dismantle as follows:

- o Loosen the valve couplings at the connection housing.
- o Turn the handle CLOCKWISE till it recoils by spring action - the paring disc in the bowl is unscrewed.
- o Undo the hinged bolts and lift off the frame hood.

The guide ring should be removed only when the height position of the paring disc has to be adjusted. Do not dismantle the connection housing unless it is necessary. For bowl dismantling see Bowl.

Height adjustment

Check the height position of the paring disc before the first starting as well as after exchange of parts that can affect the height position - see chapter L, Height Adjustment.

Assembly

Clean all parts. Carefully lubricate threads and contact surfaces. Ascertain particularly that the thread of the inlet pipe is well lubricated and that the seal ring is inserted and free from defects.

Before using the machine:

- o Clamp the frame hood with the hinged bolts.
- o Connect the valves.
- o Press down the handle and screw it ANTI-CLOCKWISE till the pipe thread engages the paring disc thread. Let up the handle and tighten it firmly.

PURIFIER BOWL with EROSION PROTECTED SLIDING BOWL BOTTOM, for COMBINED PROGRAMME -- 529366-81

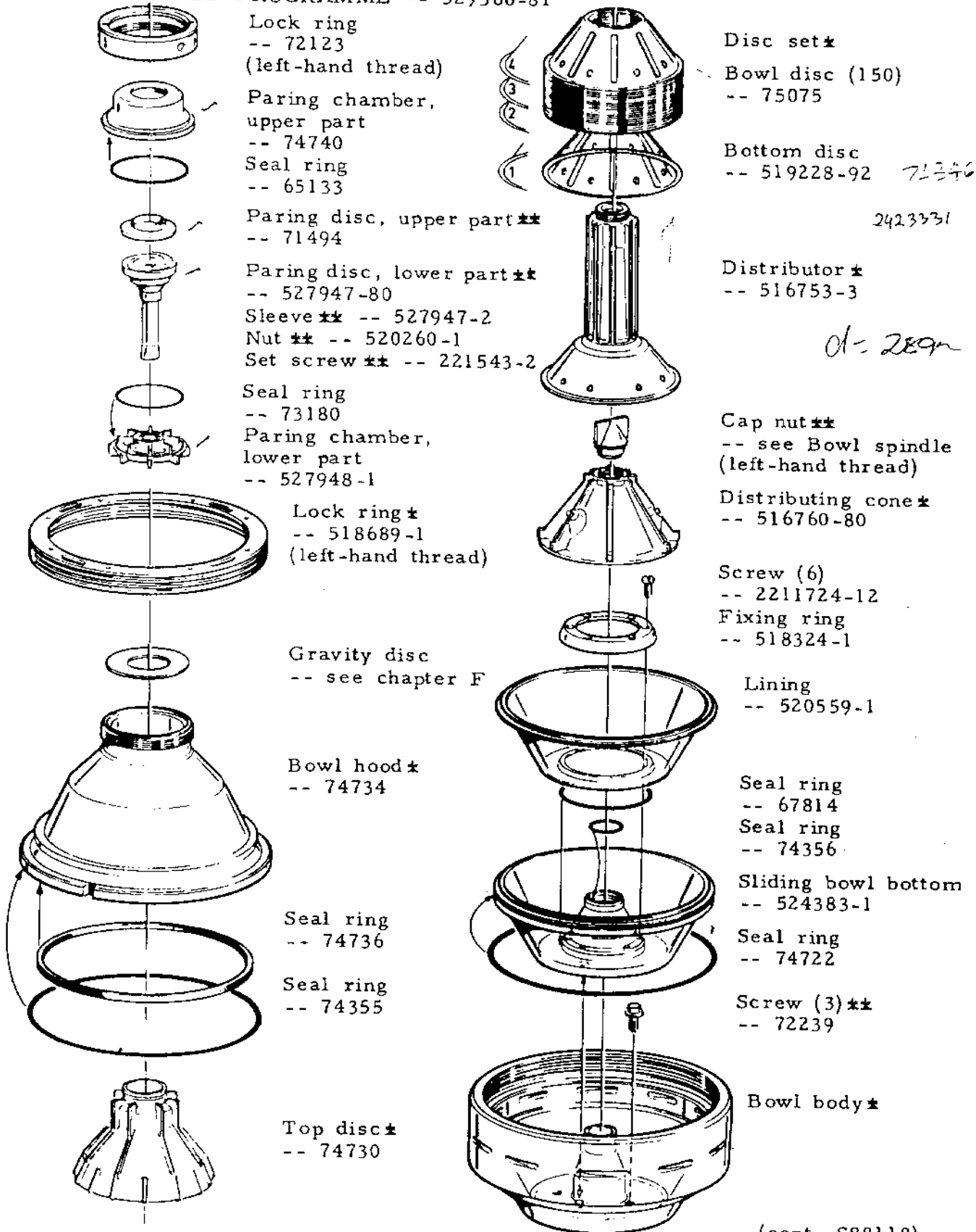

Lock ring
-- 72123
(left-hand thread)

Paring chamber,
upper part
-- 74740

Seal ring
-- 65133

Paring disc, upper part**
-- 71494

Paring disc, lower part**
-- 527947-80

Sleeve** -- 527947-2

Nut** -- 520260-1

Set screw** -- 221543-2

Seal ring
-- 73180

Paring chamber,
lower part
-- 527948-1

Lock ring*
-- 518689-1
(left-hand thread)

Gravity disc
-- see chapter F

Bowl hood*
-- 74734

Seal ring
-- 74736

Seal ring
-- 74355

Top disc*
-- 74730

Disc set*
Bowl disc (150)
-- 75075

Bottom disc
-- 519228-92 *71346*

Distributor*
-- 516753-3

Cap nut**
-- see Bowl spindle
(left-hand thread)

Distributing cone*
-- 516760-80

Screw (6)
-- 2211724-12

Fixing ring
-- 518324-1

Lining
-- 520559-1

Seal ring
-- 67814

Seal ring
-- 74356

Sliding bowl bottom
-- 524383-1

Seal ring
-- 74722

Screw (3)**
-- 72239

Bowl body*

(cont. S88118)

(Bowl for COMBINED PROGRAMME, page 2)

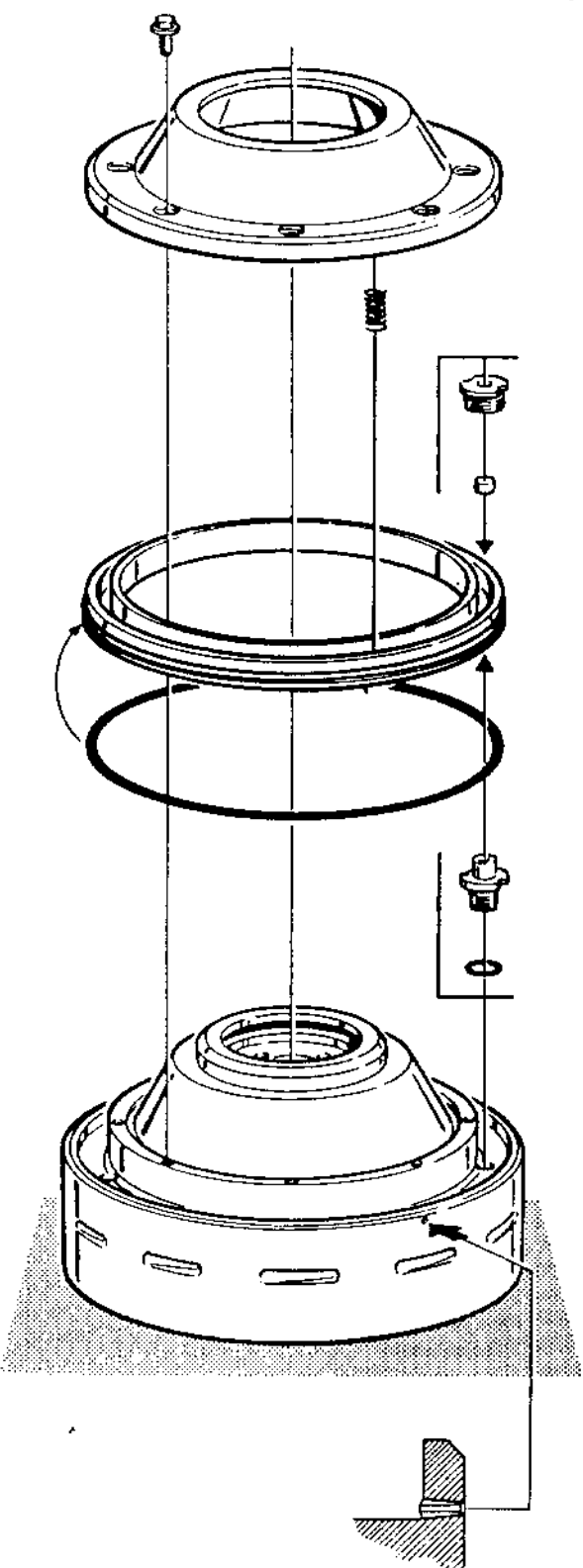

- Screw (8)
-- 72239
- Spring support
-- 74718
- Spring (18)
-- 68657
- Holder (3)
-- 519369-01
- Valve plug (3)
-- 518549-03
- Operating slide
-- 519461-01
- Seal ring
-- 74355
- Valve seat (3)
-- 536562-01
- Seal ring (3)
-- 223406-11
- Bowl body*
- Nozzle
-- 515133-3

* Exchange necessitates rebalancing - send the COMPLETE bowl to an ALFA-LAVAL representative.

** Not included in the complete-unit number.

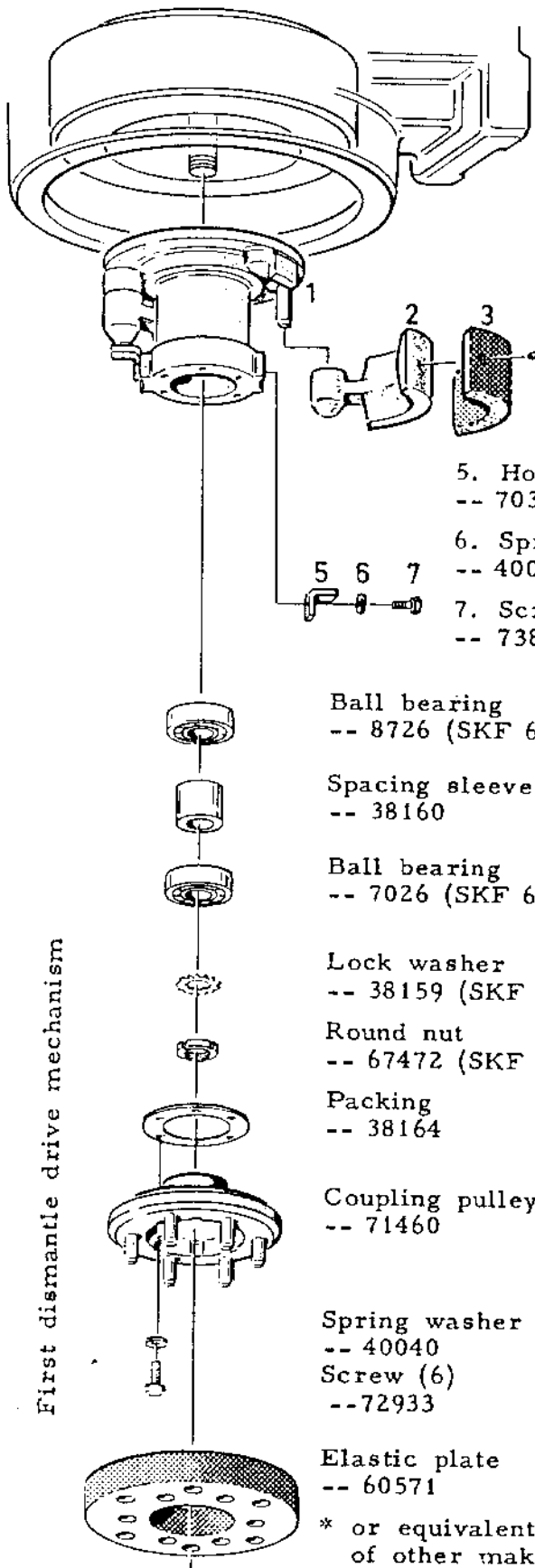

- 1. Nave
-- 70363
- 2. Friction block (4) - see Chap. F
- 3. Pad (4)
-- 71098
- 4. Screw (16)
-- 8341
- 5. Holding bracket (4)
-- 70372
- 6. Spring washer (4)
-- 40040
- 7. Screw (4)
-- 73801

- Ball bearing
-- 8726 (SKF 6206)*
 - Spacing sleeve
-- 38160
 - Ball bearing
-- 7026 (SKF 6305)*
 - Lock washer
-- 38159 (SKF MB5)
 - Round nut
-- 67472 (SKF KM5)
 - Packing
-- 38164
 - Coupling pulley
-- 71460
 - Spring washer (6)
-- 40040
 - Screw (6)
-- 72933
 - Elastic plate
-- 60571
- * or equivalent bearing of other make

The friction blocks can be removed without the necessity of dismantling the rest of the clutch.

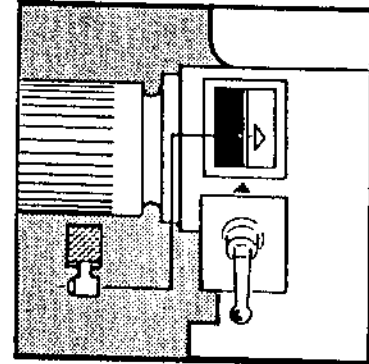

When the blocks are assembled they should move freely, and the holding brackets should be mounted so that they engage the groove in the nave and prevent the blocks from slipping off their pivots.

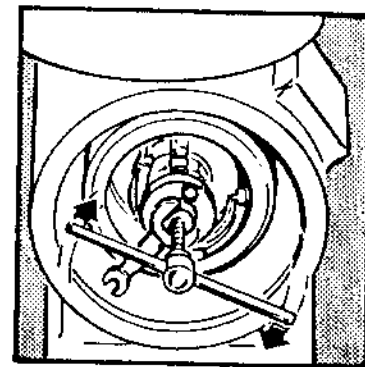

The illustration shows how the nave is eased off the shaft. To assemble, first fit the nave on the shaft and then the inner ball bearing. Pack one-third of the space about the spacing sleeve with ball bearing grease. Use the drive-on sleeve to drive the bearings into position.

First dismantle motor, clutch and frame shield (pump)

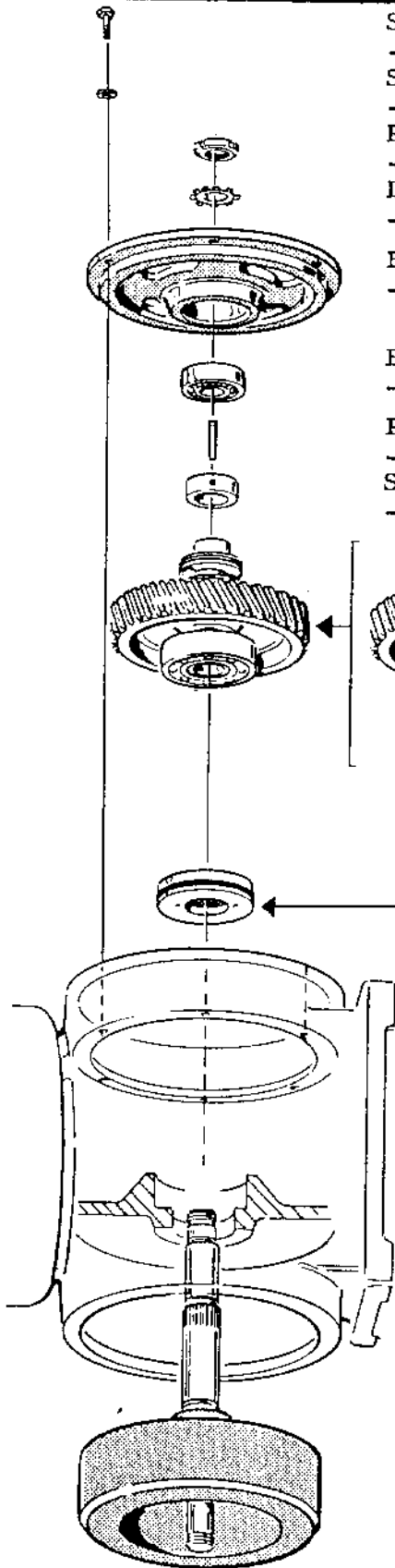

- Screw (4)
-- 65231
- Spring washer (4)
-- 62094
- Round nut
-- 67473 (SKF KM6)
- Lock washer
-- 37992 (SKF MB6)

- Bearing shield
-- 528172-2

- Ball bearing
-- 6525 (SKF 6306)*

- Pin
-- 64729
- Stop ring
-- 65170

- Worm wheel
-- see Ch. F

- Ball bearing
-- 68827
(SKF 6211)*

- Lipseal ring
-- 73547
- Seal washer
-- 528098-1
- Seal ring
-- 223412-21

Worm wheel shaft with conveyor pulley, lock washer and round nut

- | |
|------------------------------------|
| For clutch coupling
-- 70359 |
| For fixed coupling
-- 516378-01 |

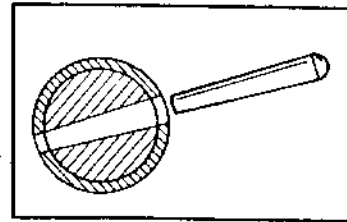

Align the stop ring correctly when fitting - both the hole and the pin are tapered (taper 0.02). if there is any play, the hole must be reamed.

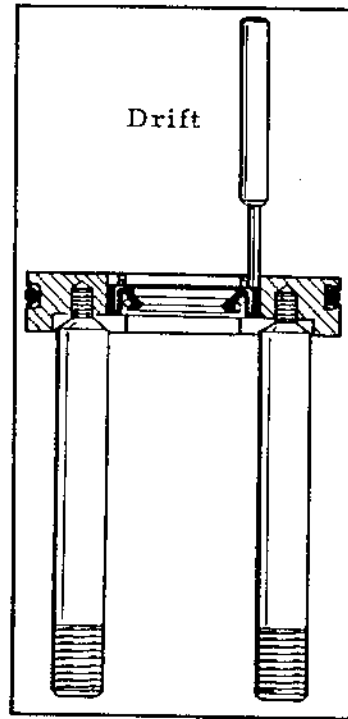

Use the motor guide bolts to draw out the seal washer. When assembling, make sure that the lipseal ring is turned as shown in the illustration. Warm the ball bearing before fitting it on the worm wheel.

* or equivalent bearing of other make

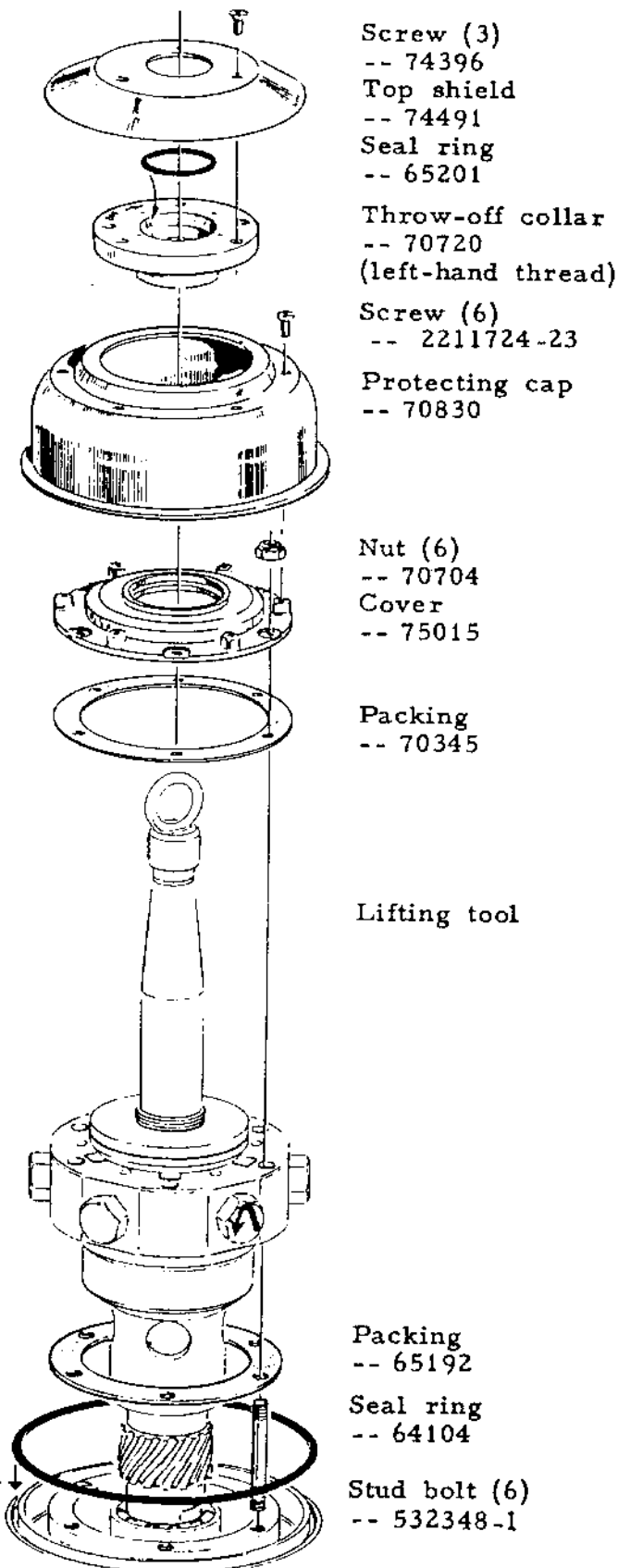

Screw (3)
-- 74396
Top shield
-- 74491
Seal ring
-- 65201
Throw-off collar
-- 70720
(left-hand thread)
Screw (6)
-- 2211724-23
Protecting cap
-- 70830

Nut (6)
-- 70704
Cover
-- 75015

Packing
-- 70345

Lifting tool

Packing
-- 65192
Seal ring
-- 64104
Stud bolt (6)
-- 532348-1

DISMANTLING and MOUNTING of COMPLETE BOWL SPINDLE

The bowl body, control valve and paring disc device for operating liquid must be removed to make the parts accessible for dismantling.

The throw-off collar is unscrewed **CLOCKWISE** with the pin spanner.

The top bearing plugs can most conveniently be unscrewed while the bowl spindle is still in place in the frame.

Before the bowl spindle can be lifted out of the machine the worm wheel must be moved along the worm wheel shaft to disengage the worm. This work can be done through the aperture covered by the revolution counter cap. To facilitate the lifting of the bowl spindle screw on the lifting tool.

When fitting the complete bowl spindle in the frame ascertain that the lower ball bearing of the worm engages the guide in the bottom bushing.

After assembling, check that the bowl spindle turns when the worm wheel shaft is rotated. Check the height adjustment (see Chapter L).

(Bowl spindle, page 2)

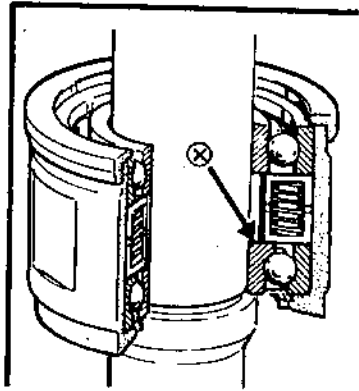
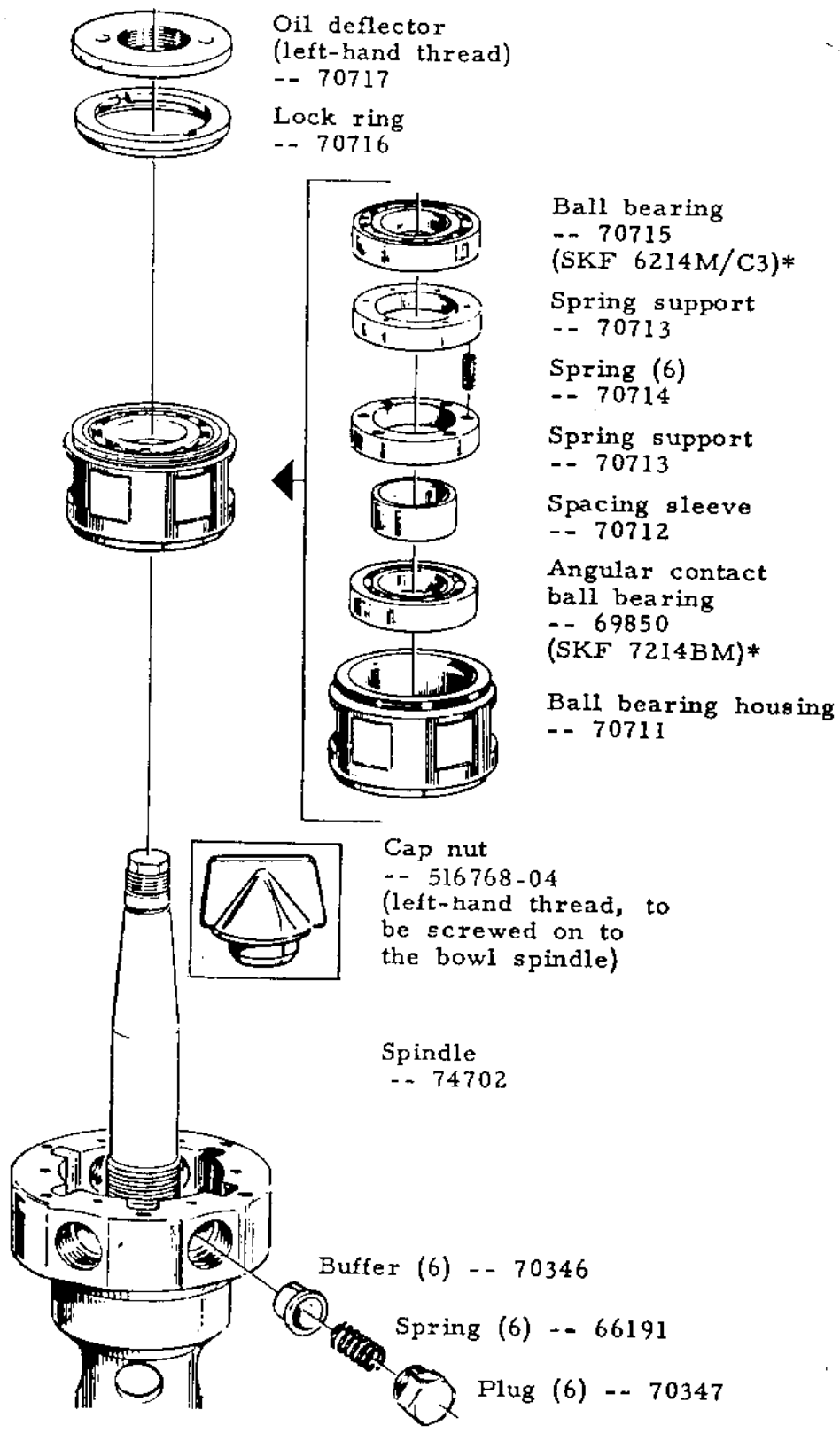

NOTE. The angular contact ball bearing must be mounted with the wide shoulder of the inner ball race facing upwards.

(cont. S89622)

(Bowl spindle, page 3)

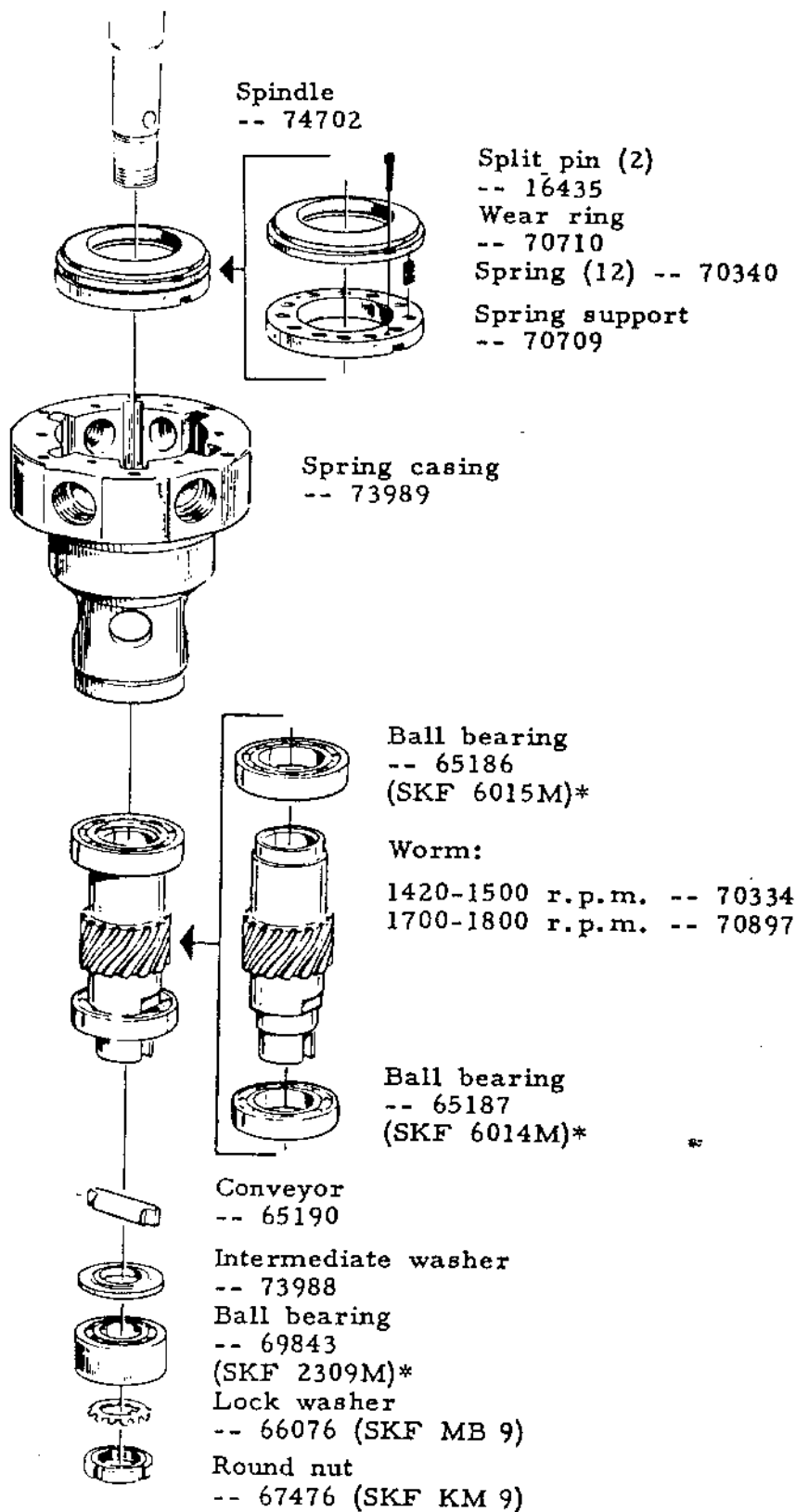

* or equivalent bearing of other make.

MOTOR ON FOUNDATION PLATE (bearing shield with nipple for ventilation of clutch coupling)

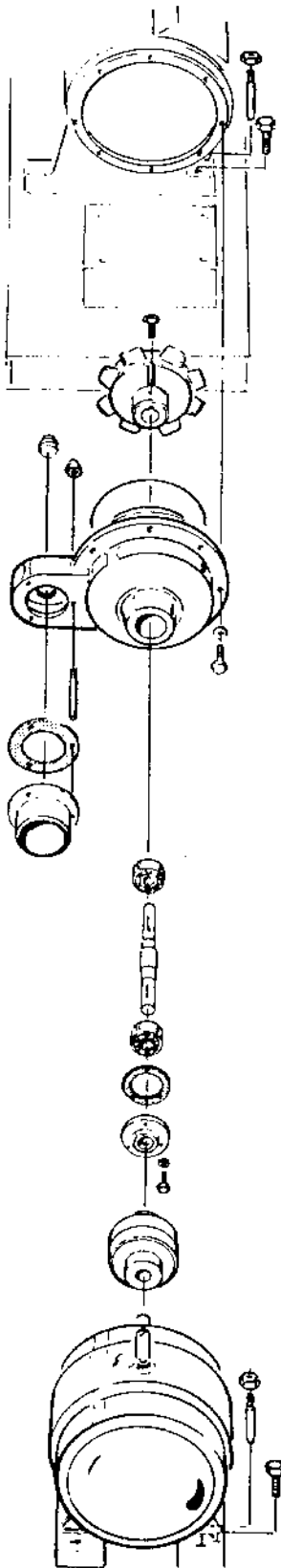

Nut (2) -- 41330
 Guide pin (2) -- 65320
 Screw (4) -- 65319

Foundation plate
 -- 60471

Set screw -- 65347

Coupling pulley
 -- 515169-2

Plug -- 66897
 Cap nut (3) -- 221854-3
 Seal ring -- 64104
 Bearing shield -- 73803

Washer (7) -- 70492
 Screw (7) -- 65231
 Stud bolt (3)
 -- 2216241-1
 Packing -- 32196

Nipple
 -- 516354-80
 Ball bearing (2) -- 38092
 (SKF 6308*)

Shaft -- 65324
 (Key -- 65325)
 (Sleeve -- 516361-1)

Packing -- 65327

Cover -- 65326
 Washer (3) -- 40040
 Screw (3) -- 34963

Coupling -- 519507-1*
 (Set screw -- 72876)

Motor and foundation are marked with the manufacturing number of the machine to which they belong. Make sure they are mounted together when installing several machines at the same time.

Push the elastic plate on to the pins of the machine coupling pulley.

Put the motor on the base blocks and push it into correct position, fitting the pins of the motor coupling pulley into the holes of the elastic plate. Fix the position of the motor with guide pins and fasten it with screws.

* When ordering -- follow the instructions given in chapter A.

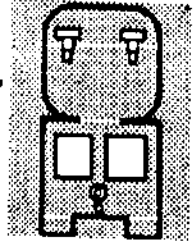

FRAME PARTS

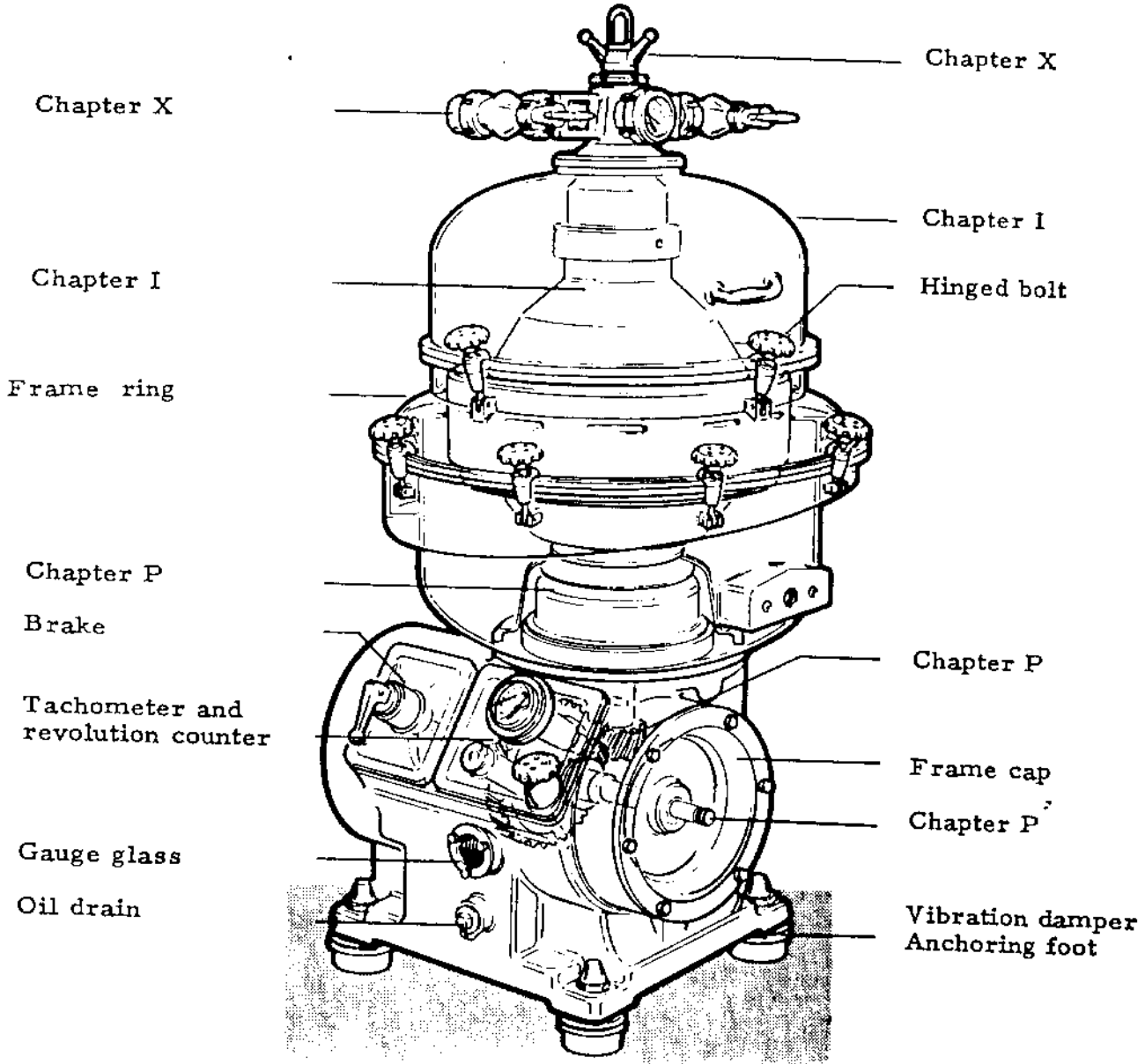

VIBRATION DAMPER (6)*

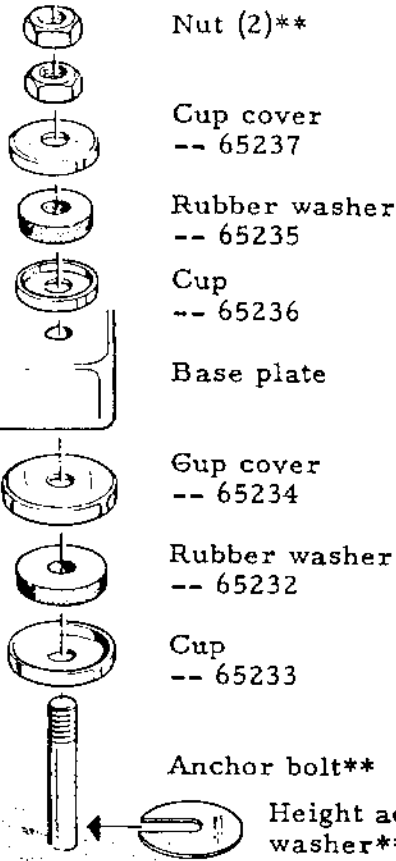

Nut (2)**

Cup cover
-- 65237

Rubber washer
-- 65235

Cup
-- 65236

Base plate

Cup cover
-- 65234

Rubber washer
-- 65232

Cup
-- 65233

Anchor bolt**

Height adjusting
washer**

* used with the foundation plate intended for collective mounting of machine and driving motor.
** not included

GAUGE GLASS

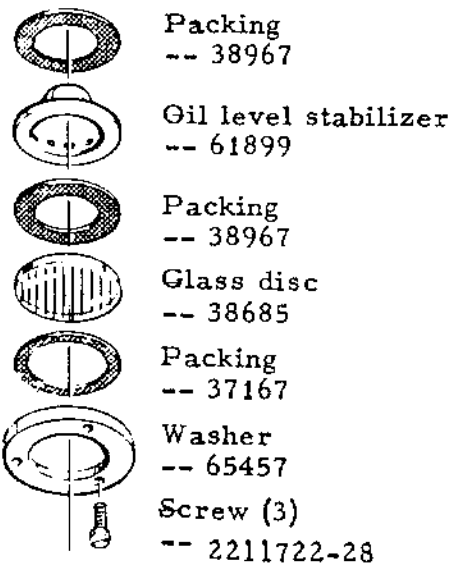

Packing
-- 38967

Oil level stabilizer
-- 61899

Packing
-- 38967

Glass disc
-- 38685

Packing
-- 37167

Washer
-- 65457

Screw (3)
-- 2211722-28

VIBRATION DAMPER (4) and FOUNDATION PLATE

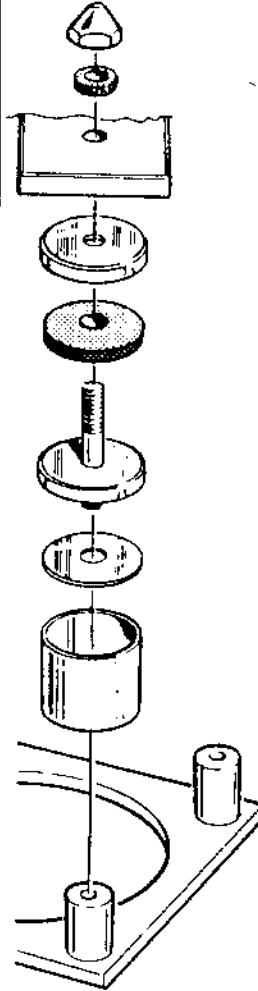

Nut
-- 424257-1
Rubber washer
-- 65235

Machine foot

Cup cover
-- 520588-1

Rubber washer
-- 65232

Stud bolt
-- 2216321-04

Cup cover
-- 520588-01

Height adjusting
washer
-- 71077

Spacing tube
-- 71074

Foundation plate for
embedment
-- 520585-80

FRAME CAP

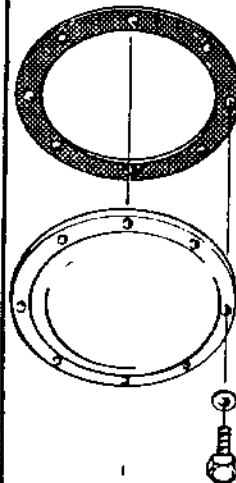

Packing
-- 37490

Cap
-- 38714

Washer (6)
-- 66381

Screw (6)
-- 65437

HINGED BOLT (8) - for frame ring

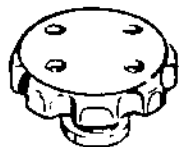

Hand wheel
-- 67885



Clamping shoe
-- 519679-2



Hinged bolt
-- 68121



Pin
-- 67783



Hinge pin
-- 71456

HINGED BOLT (4) - for frame hood



Hand wheel
-- 67885



Clamping shoe
-- 70279



Hinged bolt
-- 68121

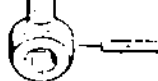

Pin
-- 67783



Hinge pin
-- 71456

OIL DRAIN

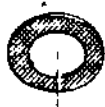

Packing
-- 35607



Screw
-- 62467

HOOD for PARING DISC DEVICE



Screw (6)
-- 67299



Washer (6)
-- 24346

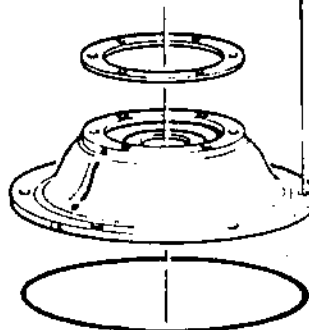

Height adjusting
rings (1-5)*
-- 67642

Hood
-- 517610-2

Seal ring
-- 67587

* Unmounted rings are packed together with the spare parts

BOTTOM BUSHING for BOWL SPINDLE

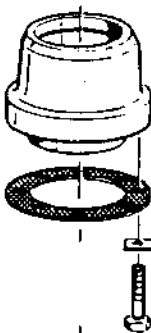

Bushing
-- 70318

Packing
-- 65211

Unlock washer (8)
-- 63256

Screw (8)
-- 65193

VENTILATION ON FRAME BOTTOM PART

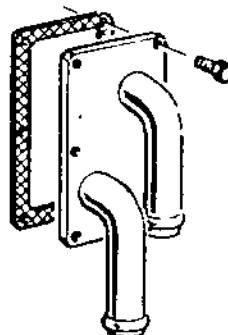

Packing
-- 519583-1

Screw (6)
-- 66379

Washer (6)
-- 65451

Cover
-- 520268-80

FRAME RING

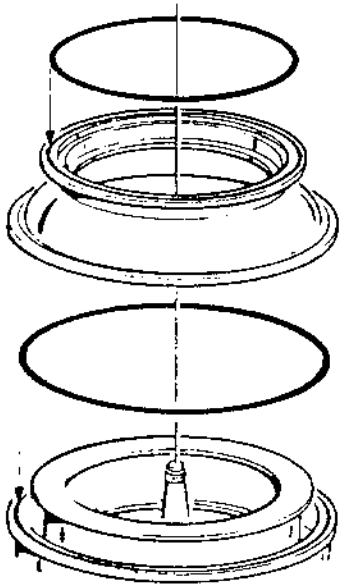

Seal ring
-- 67411

Frame ring
-- 74689

Seal ring
-- 67811

SLUDGE OUTLET

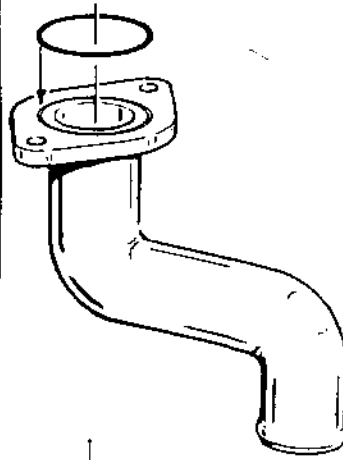

Seal ring
-- 516107-2

Tube bend
-- 516778-80



Screw (2)
-- 2210950-30

CONNECTION for FLUSHING LIQUID

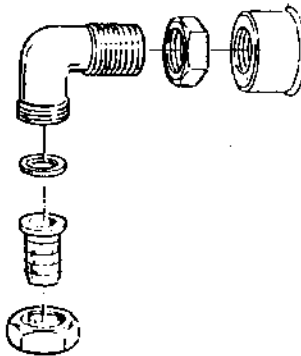

Nut
-- 71846

Pipe
-- 71845

Packing
-- 68937

Hose nipple
-- 68936

Coupling nut
-- 71343

CONTROL VALVE -- 520282-80

Plug cock For dismantling depress the disc and turn it a quarter revolution so that the recesses face the lock discs. Pull the hand wheel outwards. For cleaning see chapter L.

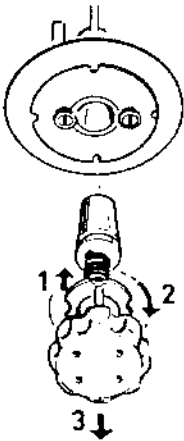

Grease the plug before mounting. Check the liquid flow - see chapter L.

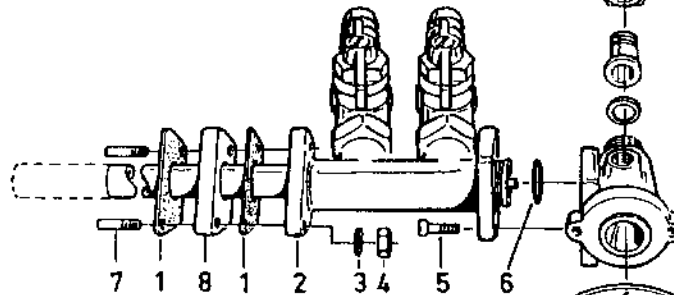

- 1 Packing (2)
-- 71923
- 2 Connection piece
-- 74763
- 3 Washer (2)*
-- 65451
- 4 Nut (2)*
-- 41380
- 5 Screw (4)
-- 11677
- 6 Seal ring
-- 64708
- 7 Stud bolt(2)*
-- 64367,
-- 2216241-4 (for spacing piece)
- 8 Spacing piece**
-- 518193-1



- Hose nipple (3)
-- 69527
- Ball valve (3)
-- 70889
- Nipple
-- 523127-3
- Strainer
-- 515482-8
- Nut (3)
-- 71343
- Nipple (3)
-- 71342
- Packing (3)
-- 223310-04
- Cock housing with plug
-- 520283-80
- Dial
-- 71053
- Lock disc (2)
-- 71331
- Screw (2)
-- 11677
- Plug
- Spring
-- 71333
- Disc
-- 71334
- Taper pin
-- 71424
- Hand wheel
-- 71335

* Not included in the complete-unit number.

** Only with certain frame types.

CONTROL DEVICE FOR OPERATING LIQUID -- 516963-81

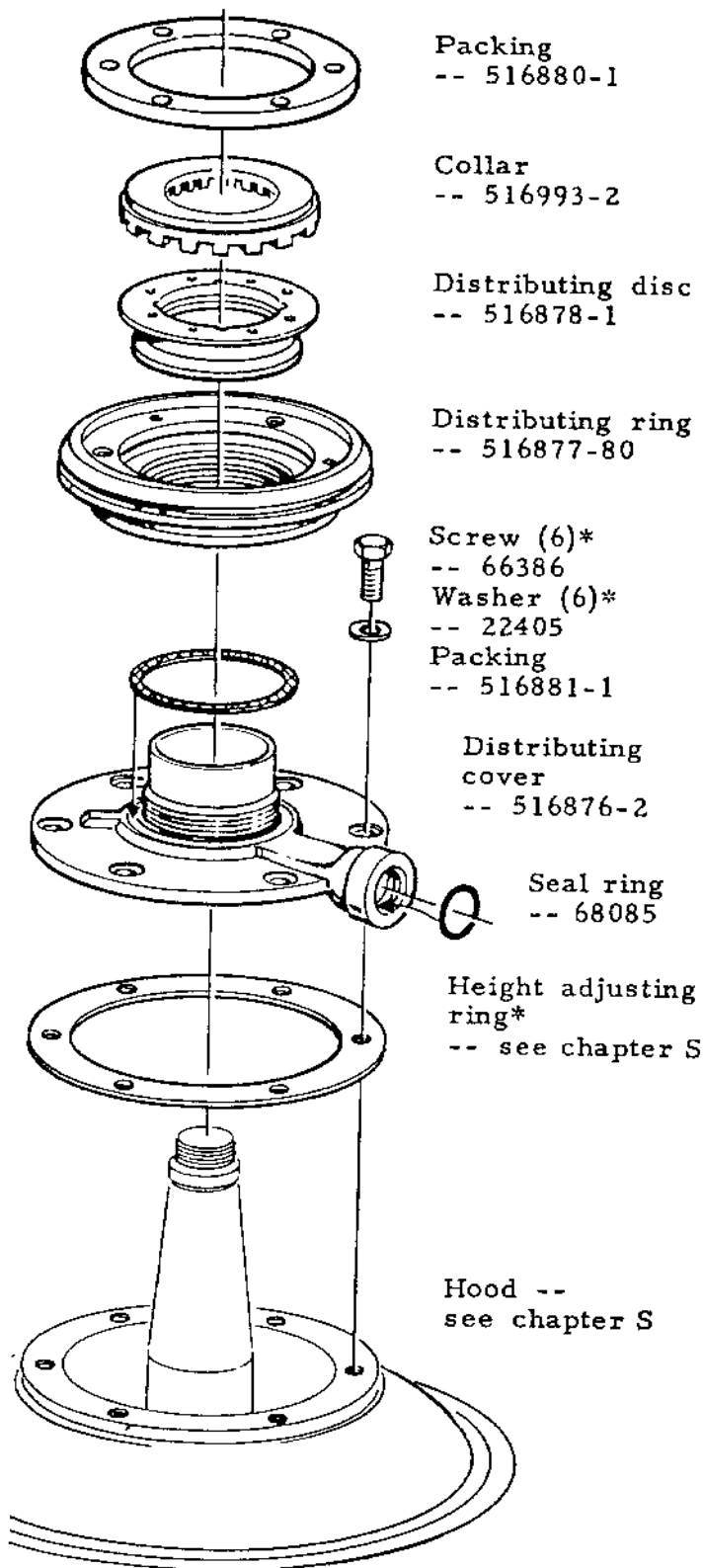

The distributing ring rotates, the other parts are non-moving.

Dismantling

For dismantling the bowl see chapter I. The distributing ring is fastened to the bowl body by screws. These screws must be removed before the bowl body can be lifted off from the spindle. Remove the packing and the collar. Screw off the distributing disc and remove the distributing ring. Use the special tools. Take out the control valve and remove the distributing cover.

Cleaning

Make sure the parts (particularly all holes and channels) are carefully cleaned — for cleaned agents see chapter L.

Assembling

Make sure that the height adjusting rings are put in place, that the parts are placed in the positions defined by the guides, that the distributing disc is tightened and that the holes in packing and distributing ring face each other. Check and fit the control valve. Supply operating liquid and check throughflow according to directions in chapter L.

* Not included in the complete-unit number.

REVOLUTION COUNTER and TACHOMETER -- 519678-80 (*-marked parts are not included in the complete-unit number)

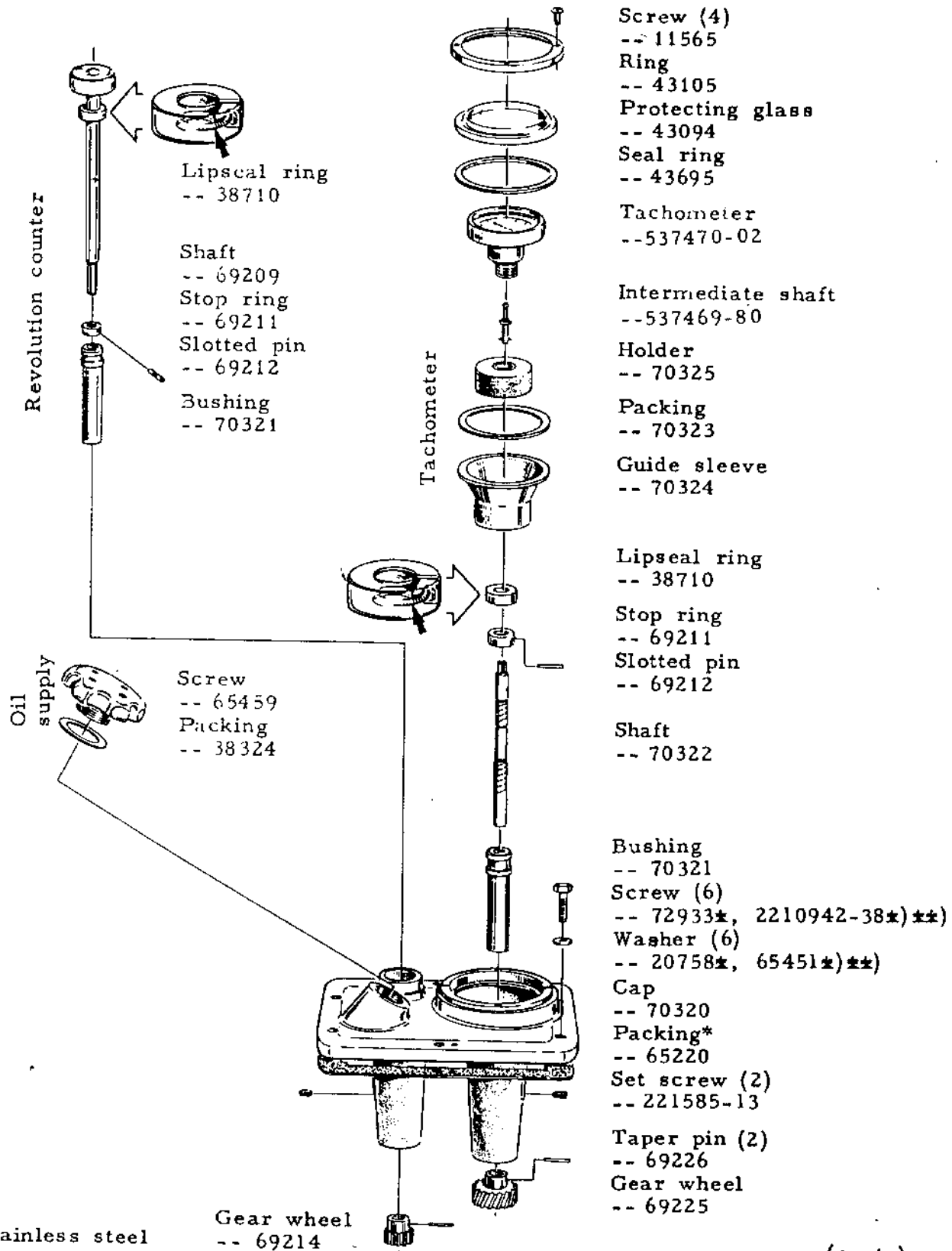

***) stainless steel

(cont.)

BRAKE -- 67799 (*-marked parts are not included in the complete-unit No.)

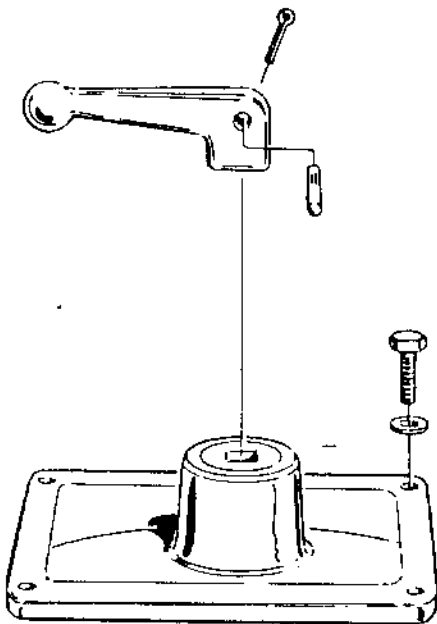

- Split pin
-- 8199
- Handle
-- 533513-1
- Pivot
-- 39098
- Screw (4)*
-- 2210942-38
- Washer (4)*
-- 65451
- Cap
-- 67786

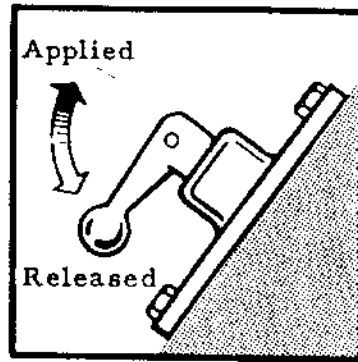

Exchange of lining
Release the brake and remove the cap. Exchange the lining. Note that the screws are slotted at both ends (use an angle driver). Fasten the cap to the machine with the handle pointing downward.

Dismantling. Assembling

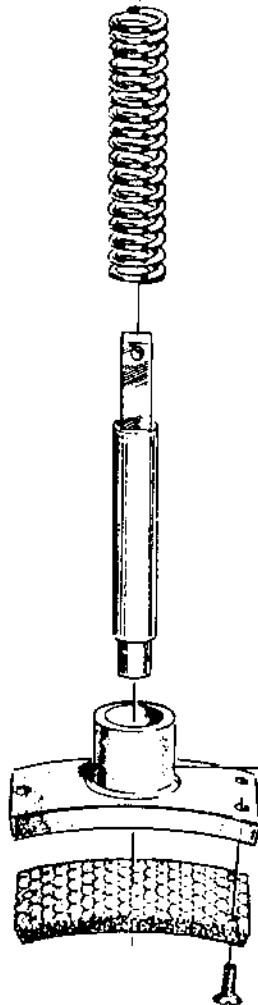

- Spring
-- 39096
- Spindle
-- 65461

- Brake shoe, compl.
- 537602-80
- Slotted pin
-- 67960
- Lining
-- 65227
- Screw (3)
-- 8341

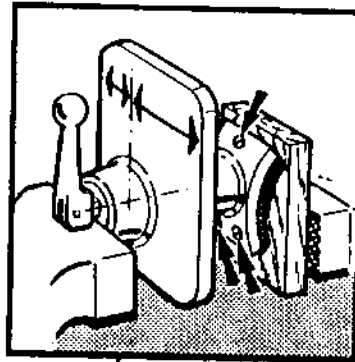

Clamp the cap in a screw vice, apply the brake, and remove the handle. See that cap, handle, and brake shoe are turned as shown by the arrows in the figure. Fasten the cap to the machine with the handle pointing downward.

CONNECTION HOUSING (with pressure gauge) -- 528088-80, (without pressure gauge) -- 528088-82

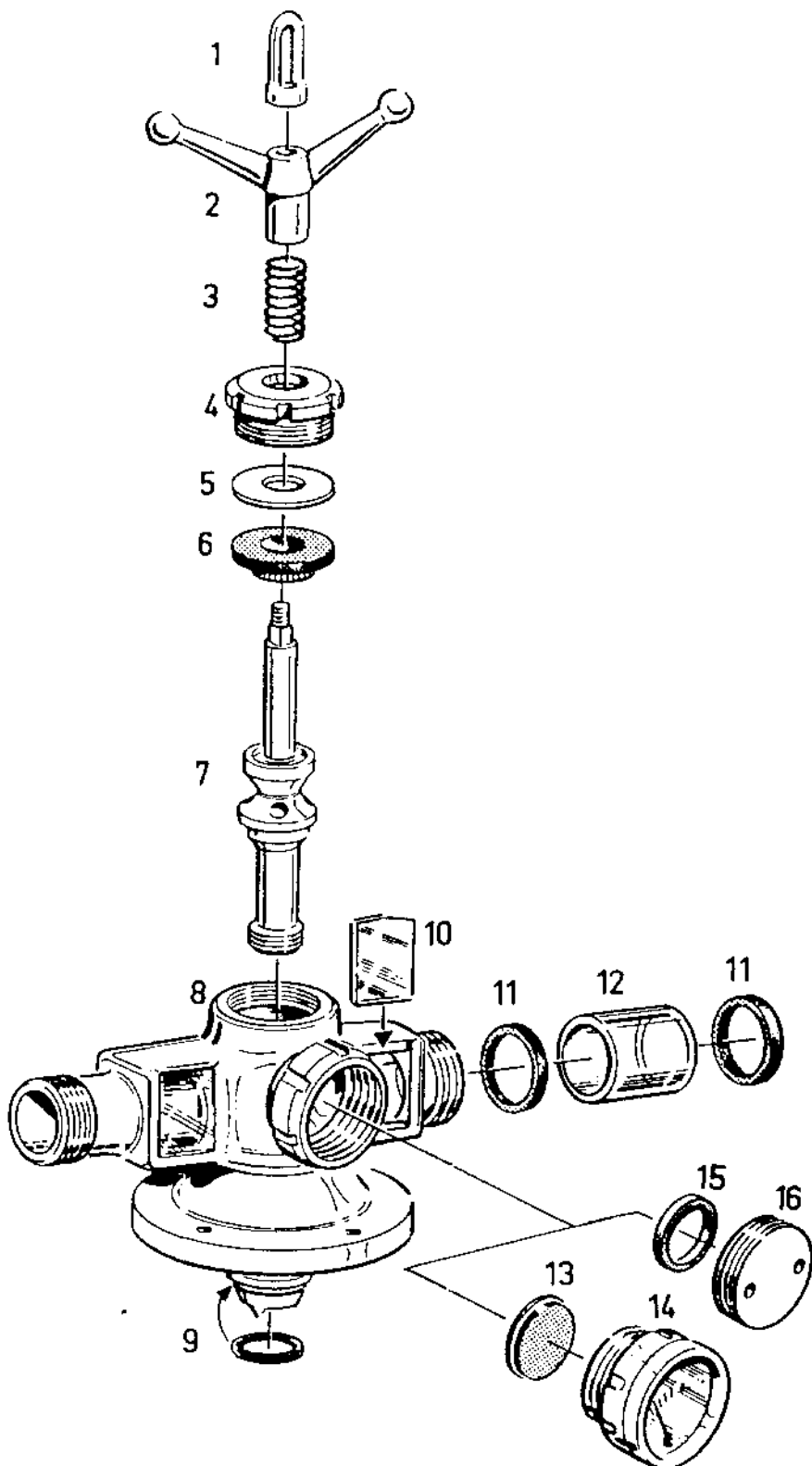

- 1 Lifting eye nut
-- 527976-2
- 2 Handle
-- 70636
- 3 Spring
-- 70634
- 4 Cap nut
-- 70635
- 5 Washer
-- 70633
- 6 Packing collar
-- 75020
- 7 Inlet pipe
-- 527974-1
- 8 Housing
-- 528003-80
- 9 Seal ring
-- 66554
- 10 Protecting glass (2)
-- 523339-1
- 11 Packing (4)
-- 71068
- 12 Sight glass (2)
-- 74565
- 13 Membrane*
-- 74384
- 14 Pressure gauge*
-- 74386
- 15 Packing**
-- 71066
- 16 Cover**
-- 74656

Set of spares

- 6 Packing collar
-- 75020
- 9 Seal ring (2)
-- 66554
- 11 Packing (4)
-- 71068
- 12 Sight glass (2)
-- 74565
- 13 Membrane*
-- 74384
- 15 Packing**
-- 71066

* Only for connection housing with pressure gauge.
 ** Only for connection housing without pressure gauge.

REGULATING VALVE without connecting parts
 REGLERINGSVENTIL utan kopplingsdelar

74414
 517697-80

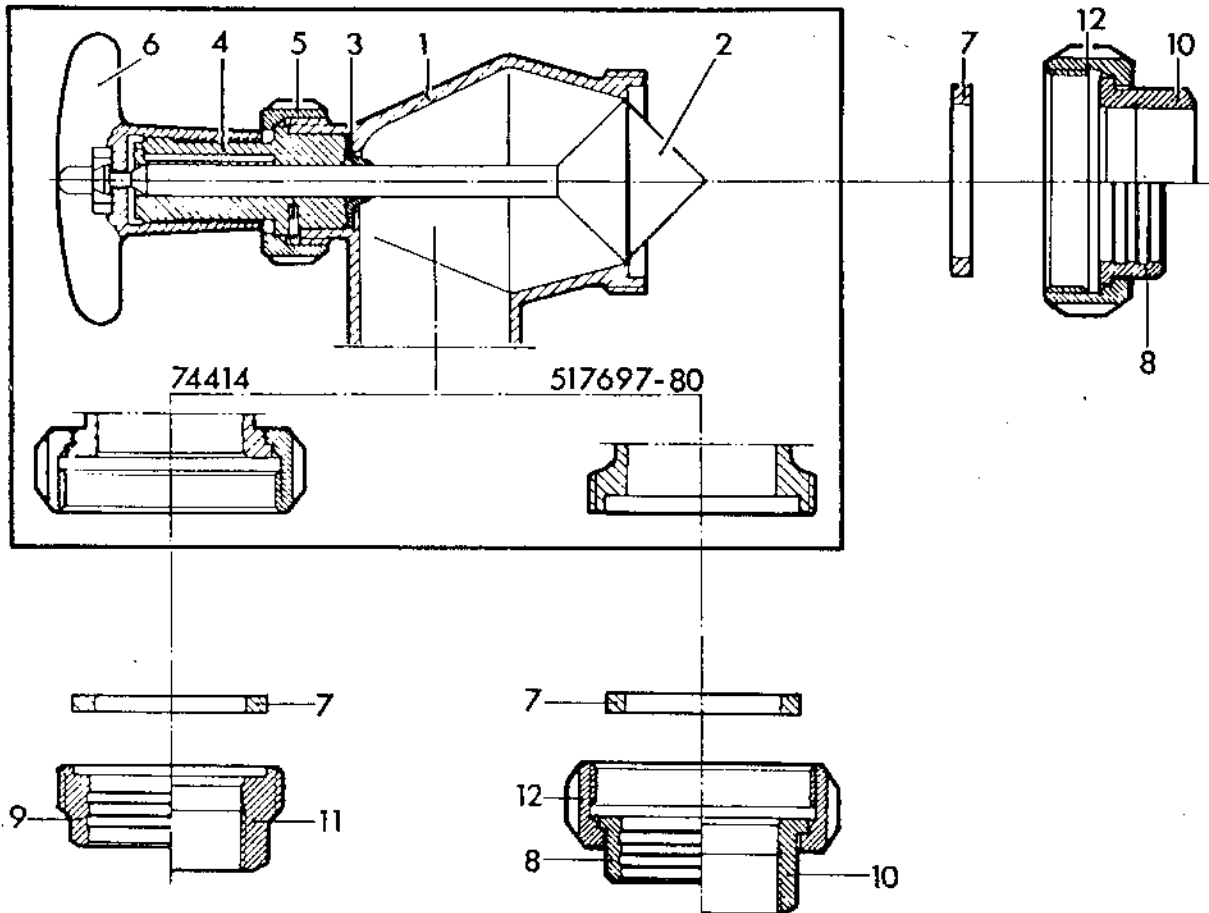

Pos.	Part No. Detalj nr.	Description	Benämning	Qty. Ant.
1.		Valve housing	Ventilhus	
2.	74421	Valve cone	Ventilkägla	
3.	74494	Packing collar	Tätningmanschett	
4.	74425	Valve bushing	Ventilbussning	
5.	190613	Coupling nut	Kopplingsmutter	
6.	518469-03	Hand wheel	Vred	
		Connecting parts	Anslutningsdelar	
7.	71068	Packing	Packning	2
8.	190630	Sleeve (even pipes) 51 mm, 2"	Hylsa (släta rör) 51 mm, 2"	
9.	190644	Nipple (even pipes) 51 mm, 2"	Nippel (släta rör) 51 mm, 2"	
10.	72234	Sleeve (threaded pipes) R 1 1/2"	Hylsa (gängade rör) R 1 1/2"	
11.	72226	Nipple (threaded pipes) R 1 1/2"	Nippel (gängade rör) R 1 1/2"	
12.	190616	Coupling nut	Kopplingsmutter	
		Spare part	Reservdel	
3.	74494	Packing collar	Tätningmanschett	

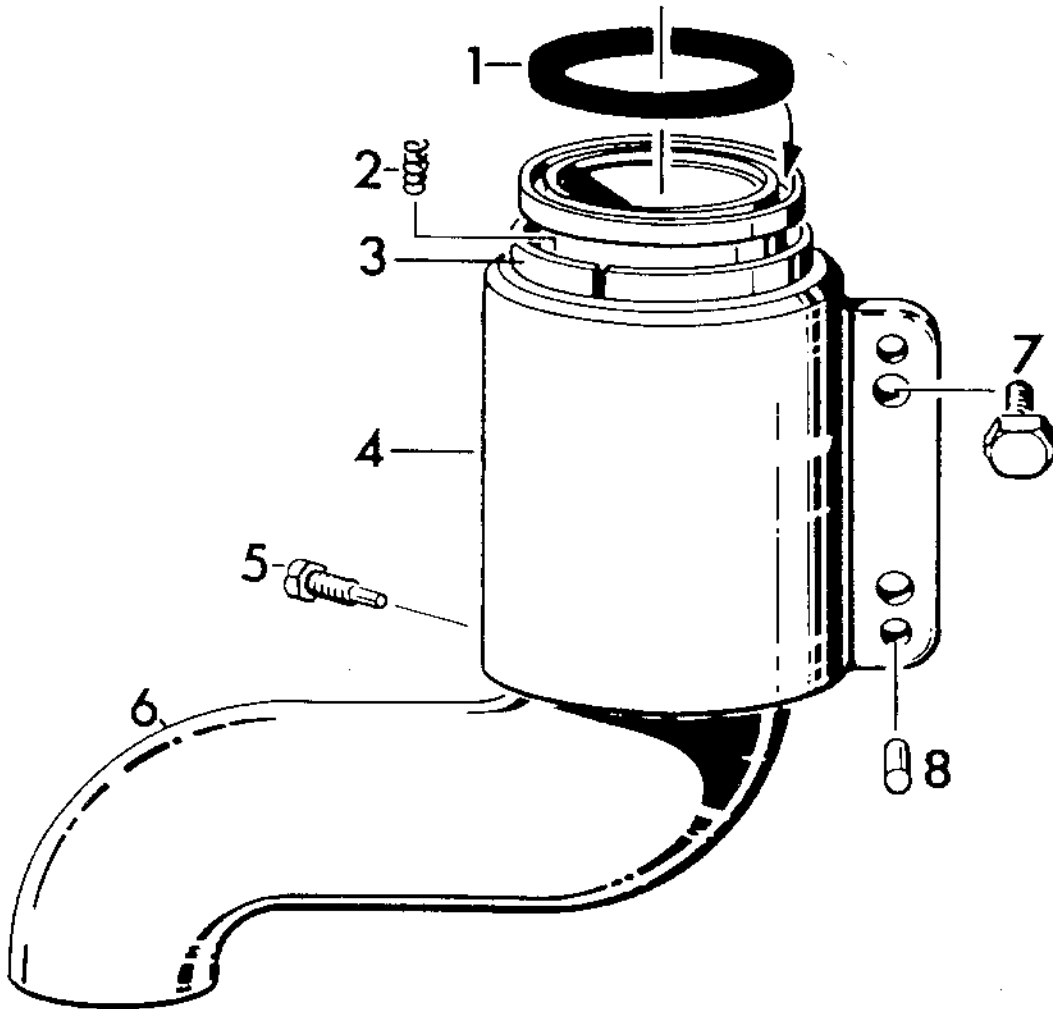

- 1 Seal ring
-- 65278
- 2 Spring (12)
-- 67405
- 3 Spring support (two parts)
-- 67404
- 4 Support
-- 67399
- 5 Set screw
-- 67406
- 6 Outlet piece
-- 69681

- 7 Screw (2)
-- 67777
- 8 Guide pin (2)
-- 67781

Set of spare parts:

- 1 Seal ring (2) -- 65278

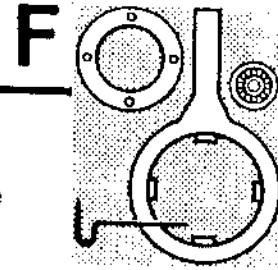

SET OF TOOLS

The special tools for the bowl are preferably hung up as close to the machine (or the cleaning place) as possible. If a tool is provided with left-hand screwed joint, this has been specially pointed out in the dismantling and assembling instructions. Notifications in this respect is not made where right-hand thread is concerned.

TOOLS FOR BOWL

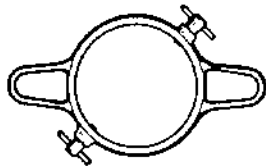

Spanner for lock ring
-- 65368

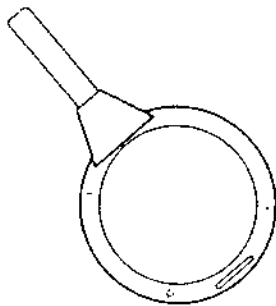

Spanner for large lock ring
-- 74783



Tin mallet
-- 64324

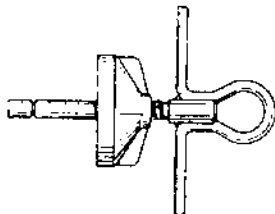

Lifting tool for bowl hood
-- 517730-80

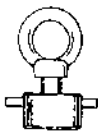

Lifting tool for distributor
-- 537315-80

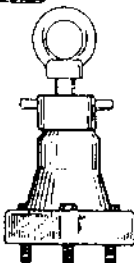

Lifting tool for distributor

Lifting tool for bowl body
-- 74776



Spanner for cap nut. Lifting tool for distributing cone
-- 516771-80



Lifting tool for sliding bowl bottom
-- 74780



Only for bowl for partial discharge:
Lifting tool (2) for level ring
-- 516866-80

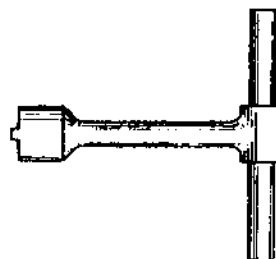

Only for bowl for combined programme:
Pin spanner for valve seating and support for valve plug
-- 519370-80

TOOLS FOR BOWL SPINDLE

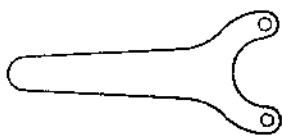

Pin spanner for lock ring, throw-off collar and oil deflector -- 65380

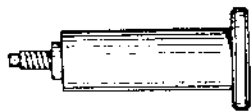

Puller for ball bearing housing -- 528514-80

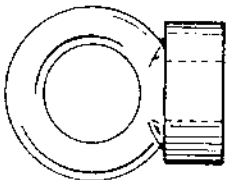

Lifting eye for bowl spindle -- 70844

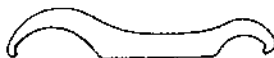

Hook spanner for round nut -- 69696

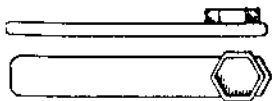

Spanner -- 70846

TOOLS FOR CLUTCH COUPLING AND WORM WHEEL SHAFT

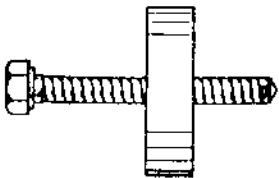

Puller for nave -- 523249-80

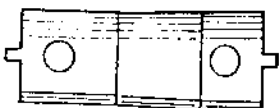

Pin spanner for round nut -- 72719



Driving-on sleeve for ball bearings of nave -- 65374

GENERAL TOOLS

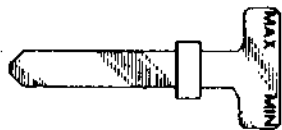

Templet for height adjustment -- 74782

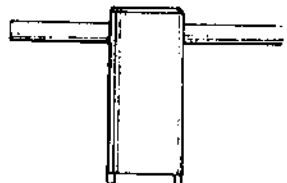

Pin spanner for control device -- 516897-80

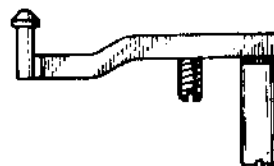

Lining-up tool for motor -- 65382 (not included when motor has been lined up before delivery)

The set of spares listed below includes only parts belonging to the standard equipment of the machine. Spare parts for special equipment are found together with the description of the latter in chapter X. In both cases make it a rule always to keep consuming articles in stock. Avoid incorrect dispatch observe the ordering routine described in chapter A.

The figure in bracket indicates the quantity (if more than one)

BOWL (comp. chapter I)		CLUTCH COUPLING. WORM WHEEL SHAFT (comp. chapter P)	
68657	Spring for operating slide (5)	70208	Friction pad (4) incl. 16 screws No. 8341
-	Bowl disc (2) - see relevant bowl	73547	Lip-seal ring
520559-1	Lining for sliding bowl bottom	223412-21	Seal ring for seal washer
Seal rings:		BOWL SPINDLE (comp. chapter P)	
74355	for bowl hood and operating slide (4)	Ball bearings:	
74736	for bowl hood	70715	for top bearing
65133	for paring chamber (4)	69843	for bottom bearing
74356	small, for sliding bowl bottom (2)	65186	for worm
67814	for lining	65187	for worm
73180	for paring chamber (2)**	69850	for ball bearing housing
<u>Additional parts depending on bowl type:</u>		Springs:	
Bowl for total discharge		70340	for axial buffer (12)
71433	Nozzle	66191	for top bearing (6)
71468	Valve plug (3)	Seal rings:	
74722	Seal ring (large) for sliding bowl bottom (2)	65201	for throw-off collar
Bowl for partial discharge		64104	for protecting cap
74355	Seal ring for level ring (2)	FRAME PARTS (comp. chapter S)	
515133-1	Nozzle	65227	Brake lining incl. 3 screws No. 8341
71468	Valve plug (3)	518859-82	Touch-up paint (tin 1/8 1)
74722	Seal ring (large) for sliding bowl bottom (2)	Seal rings:	
Bowl for combined programme		64708	for control valve
515133-3	Nozzle	67566	for hood (paring disc device)
518549-2	Valve plug (3)	67587	for hood (paring disc device)*
520243-1	Valve seat (3)	68085	for control valve
223406-11	Seal ring for valve seat (3)	38710	for tachometer shaft
74722	Seal ring (large) for sliding bowl bottom (2)	67811	for frame ring
		67411	for frame hood
		74698	for outlet bend
		516107-2	for outlet bend*
		Packings:	
		516880-1	for paring disc device
		516881-1	for paring disc device
		71068	for regulating valve (2)
		515482-36	Strainer inset
		* for machine with frame top part of stainless steel	

** only for purifier bowl

SPECIAL SPARE PART
NUMBERS

Listed below are some spare part numbers which for practical reasons have not been inserted in the chapter where they properly belong.

Gravity discs
(comp. chapter I)

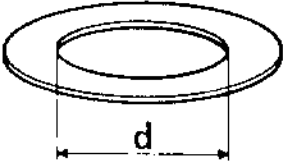
 <p>The hole diameter expressed in mm is stamped on each disc.</p>	Hole diameter in mm	Part number
	103	74741
	107	42
	111	43
	115	44
	120	45
	127	46
	134	47
	141	48
	150	49
159	50	
168	51	

Power trans-
mission
(comp. chapter P)

Machine with motorpower 15 kW (20 hk)

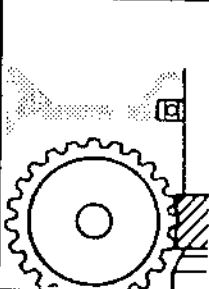
	Speed of worm wheel shaft in r.p.m.	1420 - 1500	1700 - 1800
	Worm wheel	528100-81	528100-83
	Friction block (4) with pad and screws	74489	515663-81

Machine with motorpower 18,5 kW (25 hk)

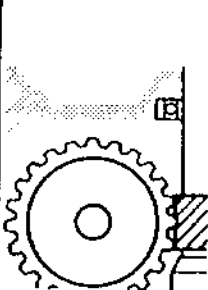
	Speed of worm wheel shaft in r.p.m.	1420 - 1500	1700 - 1800
	Worm wheel	528100-81	528100-83
	Friction block (4) with pad and screws	71978	75117

The speed of the worm wheel shaft is indicated on the type plate.

Always check that the old worm gear part and the new one have the same number of teeth.

With D.C. or A.C. 50 c/s operate the machine at a speed of 1420-1500 r/m.

With A.C. 60 c/s operate the machine at a speed of 1700-1800 r/m.