

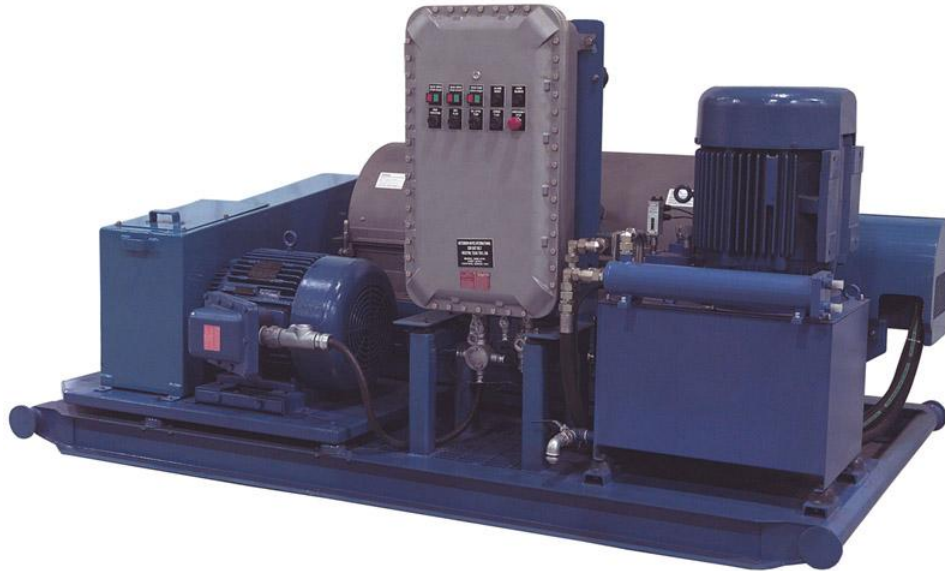

Hutchison Hayes Separation Inc.

HH 5500 Hydraulic



The HH 5500 Hydraulic is a configuration of a drive system for a Decanting centrifuge with infinite variability options on the conveying speed. This can be selected through a hydraulic system that replaces the gearbox and directly drives the Conveyor. The hydraulic drive is a closed kinetic system and is totally independent of the bowl drive, unlike all other existing conveyor drive systems the hydraulic drive unit, Rotodiff® is mounted directly on the rotating assembly, and powered from a separate power pack, or pump unit, has no influence on the bowl drive system.

The Centrifuge bowl is driven by an electric main drive motor. Main drive motor is setup with a sheave that allows simple selection of speeds, by moving the v-belt assembly.

The HH 5500 5-speed can be delivered in different variants, explosion proof for hazardous areas, sanitary for Food applications or in a normal Nema 4 execution.

Hutchison Hayes Separation Inc.
3520 East Sam Houston Beltway N.
Houston, Texas 77015, USA
Phone 713 455 9600

www.hutchisonhayes.com
P.O.Box 2965
Houston, Texas 77252, USA
Fax 713 455 7753



Hutchison Hayes Separation Inc.

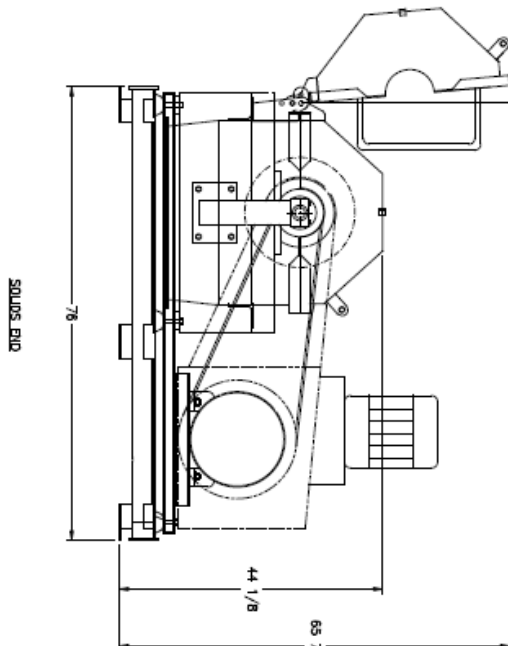
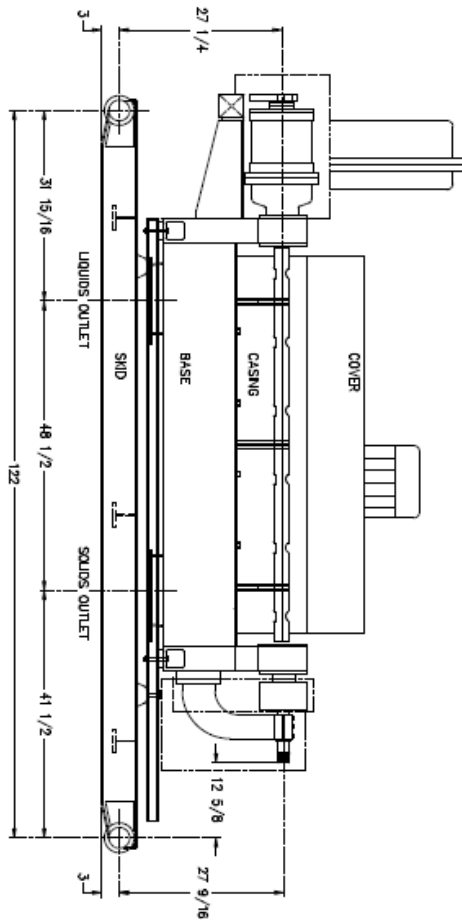

Hutchison Hayes Separation Inc.
3520 East Sam Houston Beltway N.
Houston, Texas 77015, USA
Phone 713 455 9600

www.hutchisonhayes.com
P.O.Box 2965
Houston, Texas 77252, USA
Fax 713 455 7753